



LIBERTY

MEMBER OF



**Zábradelní svodidlo
Vehicle parapet**

ZSNH4-2/H2-1

September 2023



Úroveň zadržení
Containment level

H2

Index prudkosti nárazu
Acceleration severity index

B

Pracovní šířka
Working width

W2

Hmotnost systému bez výplně
System weight without infill

47,77 kg/m

Zábradelní svodidlo Vehicle parapet

ZSNH4-2/H2-1

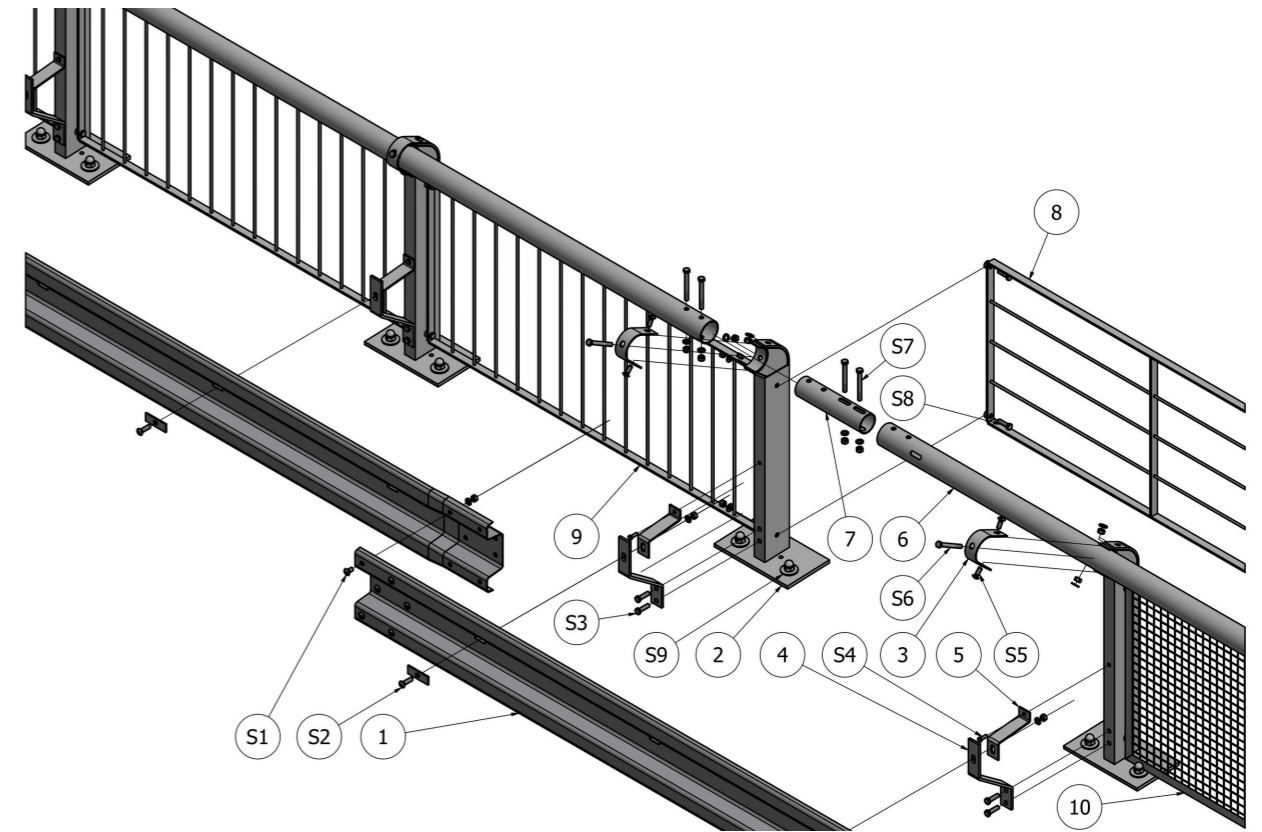
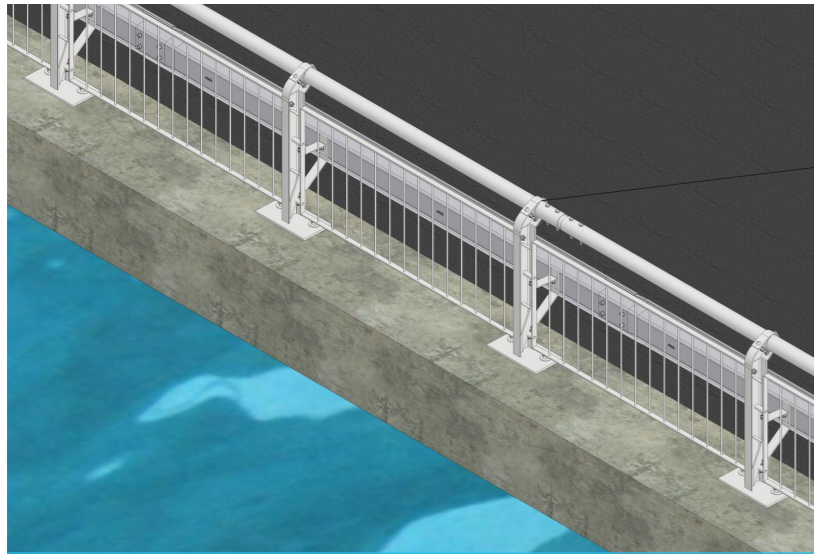

Název dílu	Pozice Position	Materiál Material	Číslo dílu Component No.	KS/4m PCS/4m	Designation
Svodnice NH4	1	S235JR	50.0.00	1	Barrier strip NH4
Sloupek ZS-4 pravý ALFA%/BETA% (740/445)	2	S355JR+S235JR	91.4.15	2	Post ZS-4 for vehicle parapet, right side ALFA%/BETA%
Třmen madla	3	S235JR	91.4.27	2	U-strap
Distanční díl MS4/ZMS4/H2	4	S355J2	92.0.01	2	Spacer MS4/ZMS4/H2
Vzpěra MS4/ZMS4/H2	5	S355J2	92.0.02	2	Spacer bracener MS4/ZMS4/H2
Madlo 3970 pravé	6	S235JRH	93.0.00	1	Handrail 3970 right
Spojka madla	7	S235JRH	93.3.00	1	Handrail joint
Výplň VT/445/2	8	S235JR+JRH	94.2.00	2	Vehicle parapet infill VT/445/2
Výplň ST/445/2	9	S235JR+JRH	94.2.01	2	Vehicle parapet infill ST/445/2
Výplň S/445/2	10	S235JR+JRH	94.2.02	2	Vehicle parapet infill S/445/2

Název dílu	Pozice Position	Číslo dílu Component No.	KS/4m PCS/4m	Designation
Šroub s polokruhovou hlavou a nosem M16x30-4.6-tZn	S1	59.0.80	8	Cup nib bolt M16x30-4.6-tZn
Matice M 16-6-tZn		59.2.40	8	Nut M16-6-tZn ISO 4032
Podložka 17,5-tZn (ø 17,5/30/3)		59.4.40	8	Washer 17.5-tZn (ø 17,5/30/3)
Šroub s polokruhovou hlavou a nosem M16x55-4.6-tZn	S2	59.0.82	2	Cup nib bolt M16x55-4.6-tZn
Matice M 16-8-tZn		59.2.41	2	Nut M16-8-tZn ISO 4032
Podložka 17,5-tZn (ø 17,5/30/3)		59.4.40	2	Washer 17.5-tZn (ø 17,5/30/3)
Krycí podložka M16		59.4.80	2	Backplate M16
Šroub se šestihrannou hlavou M16x55-8.8-tZn	S3	59.0.46	4	Hexagonal bolt M16x55-8.8-tZn
Matice M 16-8-tZn		59.2.41	4	Nut M16-8-tZn ISO 4032
U-podložka 18-tZn (klínová)		59.4.72	4	U washer 18-tZn (taper washer)
Šroub se šestihrannou hlavou M12x35-8.8-tZn	S4	59.0.22	2	Hexagonal bolt M12x35-8.8-tZn
Matice M 12-8-tZn		59.2.21	2	Nut M12-8-tZn ISO 4032
U-podložka 14-tZn (klínová)		59.4.71	2	U washer 14-tZn (taper washer)
Šroub s polokruhovou hlavou a nosem M16x40-4.6-tZn	S5	59.0.81	4	Cup nib bolt M16x40-4.6-tZn
Matice M 16-8-tZn		59.2.41	4	Nut M16-8-tZn ISO 4032
Podložka 17,5-tZn (ø 17,5/30/3)		59.4.40	4	Washer 17.5-tZn (ø 17,5/30/3)
Šroub se šestihrannou hlavou M16x140-8.8-tZn	S6	59.0.42	2	Hexagonal bolt M16x140-8.8-tZn
Matice M 16-8-tZn		59.2.41	2	Nut M16-8-tZn ISO 4032
Podložka 17,5-tZn (ø 17,5/30/3)		59.4.40	2	Washer 17.5-tZn (ø 17,5/30/3)
Šroub se šestihrannou hlavou M16x140-8.8-tZn	S7	59.0.42	4	Hexagonal bolt M16x140-8.8-tZn
Matice M 16-8-tZn		59.2.41	4	Nut M16-8-tZn ISO 4032
Podložka 17,5-tZn (ø 17,5/30/3)		59.4.40	4	Washer 17.5-tZn (ø 17,5/30/3)
Šroub se šestihrannou hlavou M16x55-8.8-tZn	S8	59.0.46	2	Hexagonal bolt M16x55-8.8-tZn
Matice M 16-8-tZn		59.2.41	2	Nut M16-8-tZn ISO 4032
Podložka 18-tZn (ø 19/40/4)		59.4.41	2	Washer 18-tZn (ø 19/40/4)
Kotva M24	S9		4	Anchor M24 or Anchor rod M24

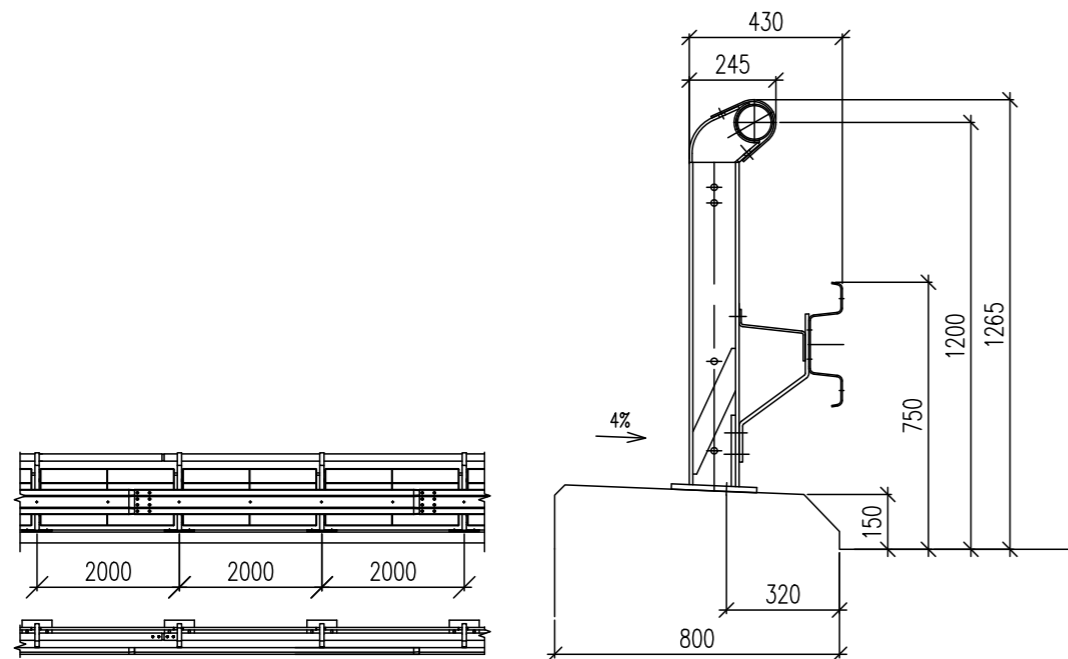

Zábradelní svodidlo Vehicle parapet

ZSNH4-2/H2-1

Zadržný systém byl testován a certifikován podle řady norem EN 1317. Všechny díly jsou žárově zinkovány podle EN ISO 1461:2009

Restraint system was tested and certified in accordance with the standards EN 1317. All parts are hot dip galvanized in accordance with the EN ISO 1461:2009



1020
Liberty Ostrava a.s.
Vratimovská 689
707 02 Ostrava-Kunčice, Czech Republic
Tel: +(420) 595 681 111

22

Číslo: 1020-CPR-090-055204

EN 1317-5:2007+A2:2012/AC:2012

Výrobek: Silniční záchranný systém

Varianta: Ocelové silniční svodidlo zábradelní

ZSNH4-2/H2-1

Trvanlivost:	Uvedeno v Prohlášení o vlastnostech č. LO/43/2022/CZ
Úroveň zadržení:	
Prudkost nárazu:	
Pracovní šířka:	
Dynamický průhyb:	
Vychýlení vozidla:	



Nebezpečné vlastnosti:

Úroveň zadržení
Containment level

H2

Test EN 1317



TB 11 900 kg; 100 km/h



TB 51 13 000 kg; 70 km/h

Index prudkosti nárazu
Acceleration severity index

B

ASI = 1,1

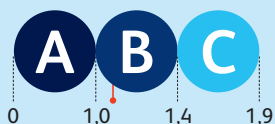

Pracovní šířka
Working width

W2

W=0,8 m, D=0,5 m



Hmotnost systému bez výplně
System weight without infill

47,77 kg/m

Se zábradelní výplní z vodorovných tyčí
With Vehicle parapet infill with horizontal bars

56,74 kg/m

Se zábradelní výplní ze svislých tyčí/
With Vehicle parapet infill with vertical bars

57,57 kg/m

Se zábradelní výplní ze svařované sítě
With Vehicle parapet infill with welded grid

56,36 kg/m

Odolnost svodidla proti odklizení sněhu
Resistance to snow removal

4

Liberty Ostrava a.s., Vratimovská 689/117
719 00 Ostrava-Kunčice Czech Republic

T +420 595 684 700
+420 595 685 627
+420 595 684 590

E tomas.hamalcik@libertysteelgroup.com

W libertysteelgroup.com/cz/
libertysteelgroup.com