

Vedere din D

STAS	0.480
C.11	0.460
	0
φ160h9	0.100

D  
↓

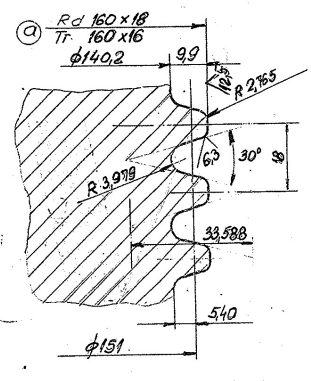
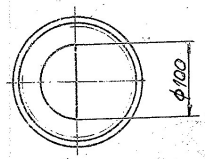

Scara: 1:1

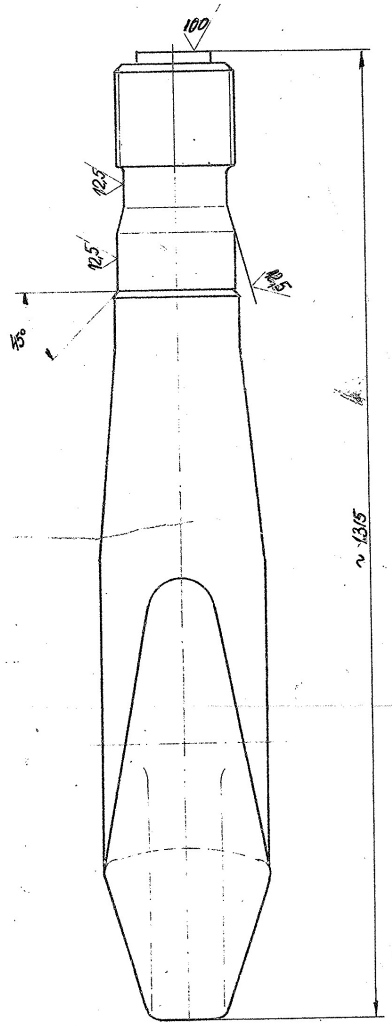
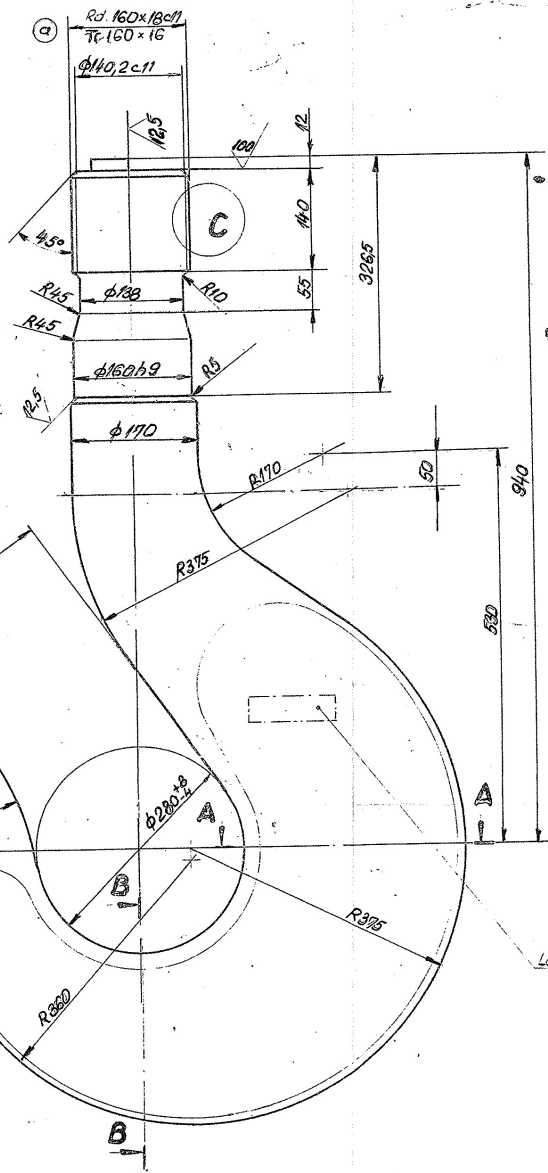

Secțiunea A-A

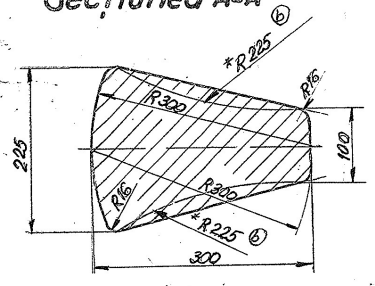

Secțiunea B-B

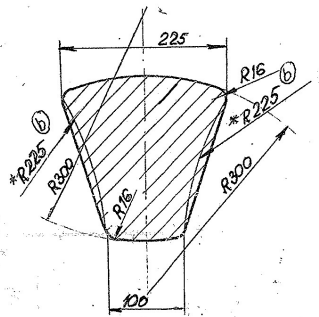

Observatii:

- Tratament termic: Normalizare conform STAS 880
- Se va marca conform STAS 1944
- Tija filetata se poate executa in doua variante: cu filet Rd 160x18 sau cu filet Tr 160x16
- Qindigul se executa prin forjare in matrita se admite si forjare libera
- \* Pentru forjare in matrita
- Mărimē 20 sarcina de incercare 100t

2	Proiect STAS 512001.129	5.12.001.129
0	Completat de: [Signature]	
5	Modificat de: [Signature]	
3	Intrat in fabrica [Signature]	
Proiectant: Casaru M.		DLC 35 STAS 880
Desenat: [Signature]		Cs.63-1
Verificat: [Signature]		
Aprobare: [Signature]		
ICPEHR		1.5
		CÂRLIG SIMPLU 63