



**LIBERTY**

MEMBER OF



## Jednostranné svodidlo Single-sided safety barrier

# J4A-1/H3-1

May 2021

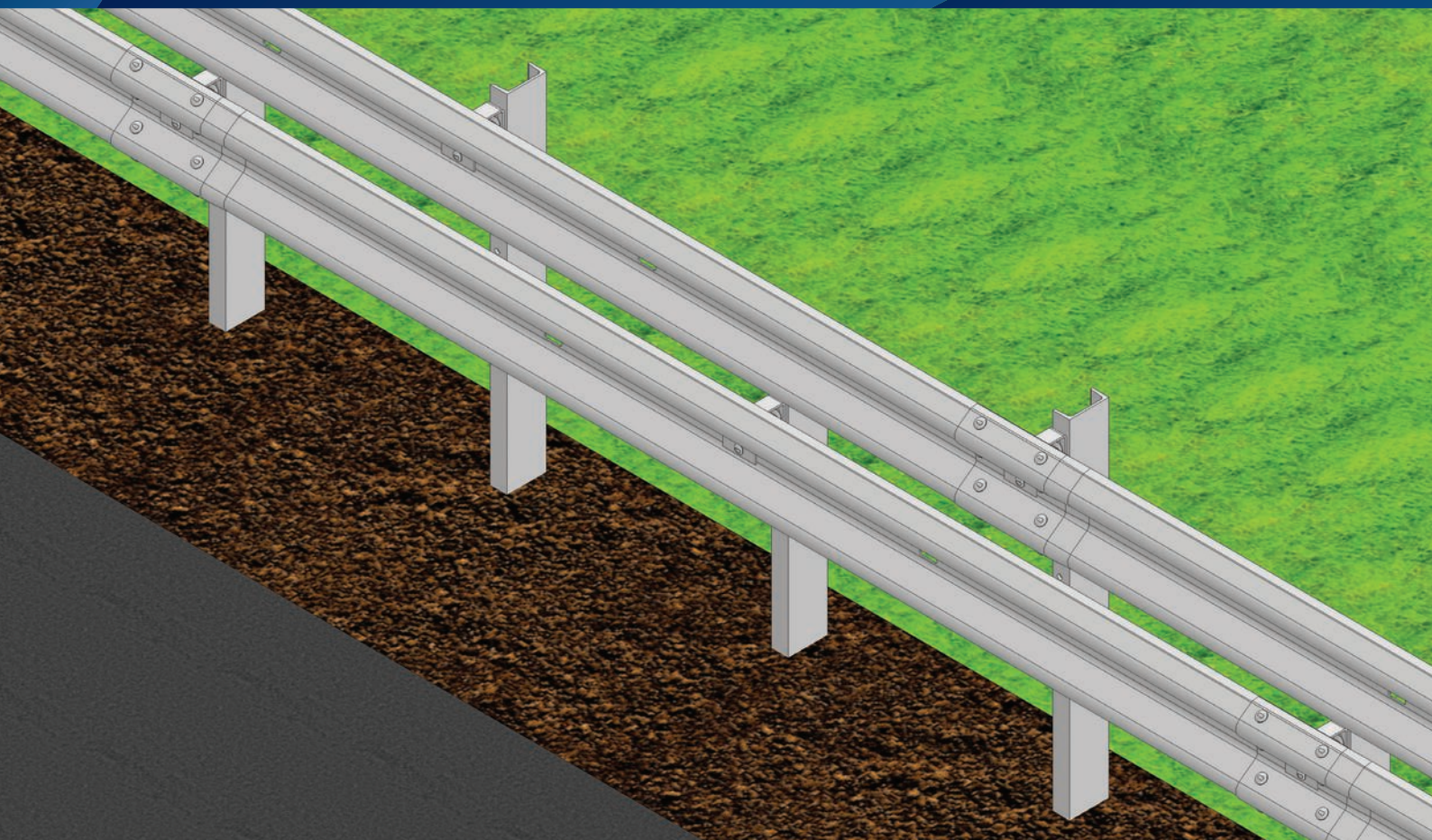

Úroveň zadržení  
Containment level

**H3**

Index prudkosti nárazu  
Acceleration severity index

**B**

Pracovní šířka  
Working width

**W6**

Hmotnost systému  
System weight

**73,14 kg/m**

Jednostranné svodidlo  
Single-sided safety barrier



J4A-1/H3-1

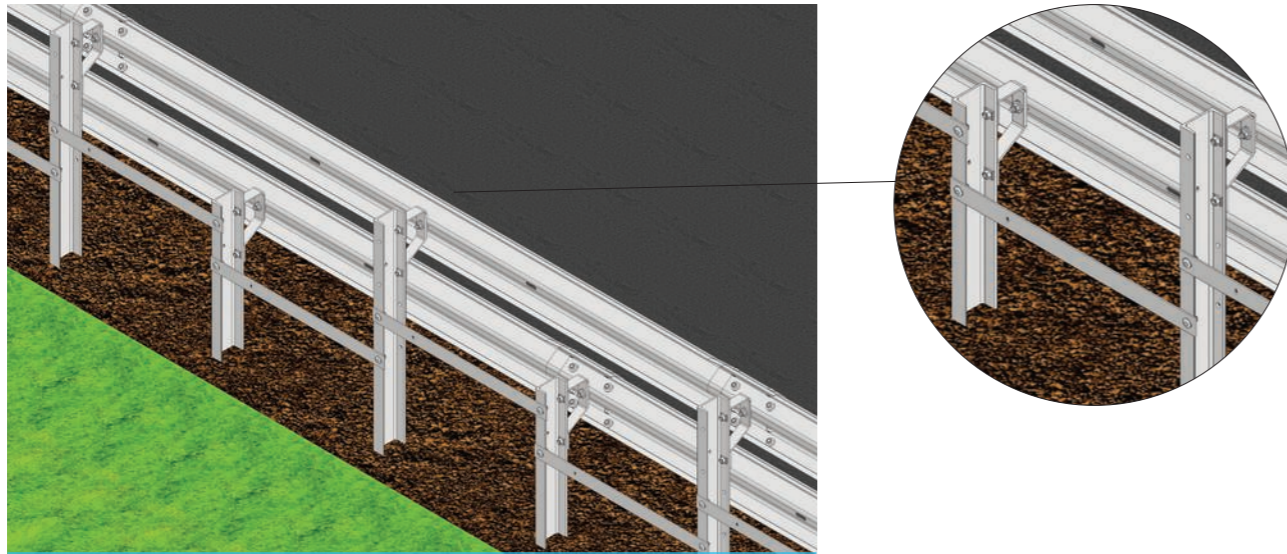

Název dílu	Pozice Position	Materiál Material	Číslo dílu Component No.	Ks/4m Pcs/4m	Designation
Svodnice A-AM-19/4	1	S235JR	70.0.02	2	Barrier strip A-AM-19/4
Sloupek U140 A-H3 I	2	S235JR	71.2.20	2	Post U140 A-H3 I
Sloupek U140 A-H3 II	3	S235JR	71.2.21	2	Post U140 A-H3 II
Distanční díl JM1	4	S355JR	62.0.00	4	Spacer JM1
Distanční díl JM2	5	S355JR	62.0.01	4	Spacer JM2
Zadní pásek 1072	6	S235JR	75.0.01	4	Back strap 1072

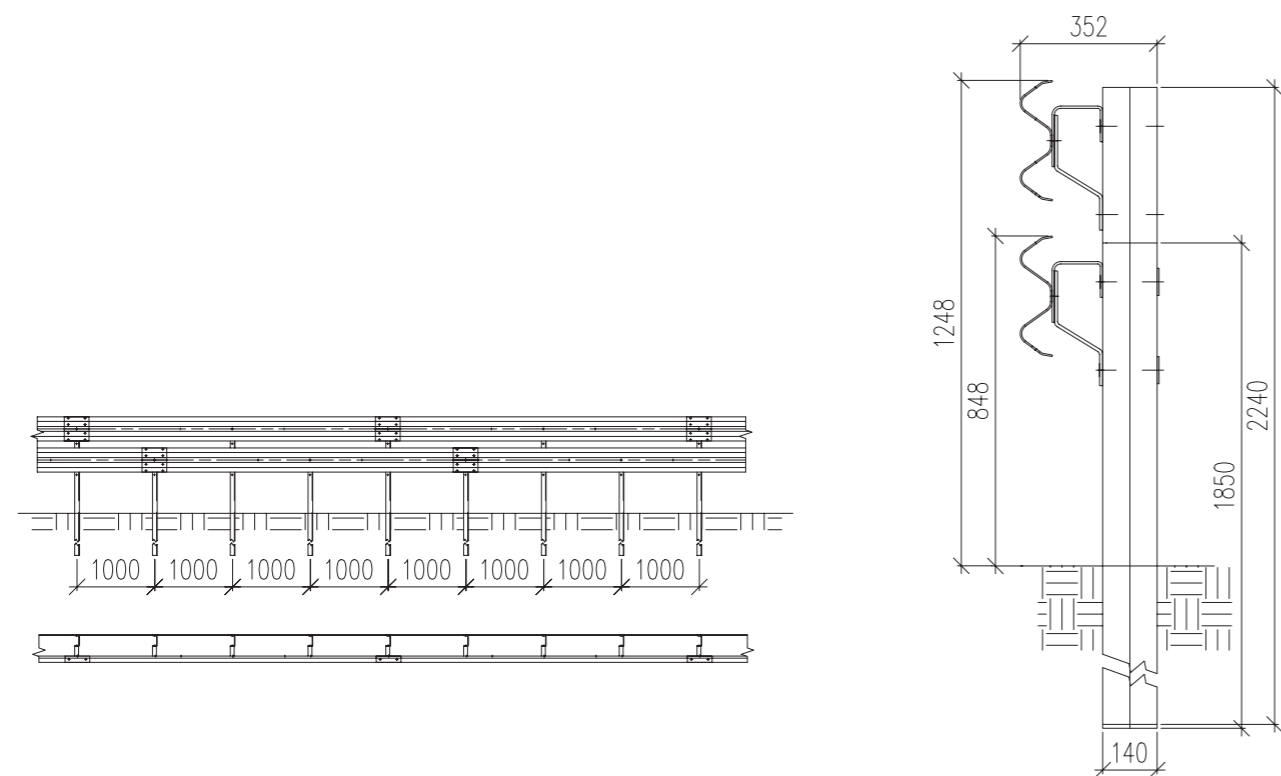
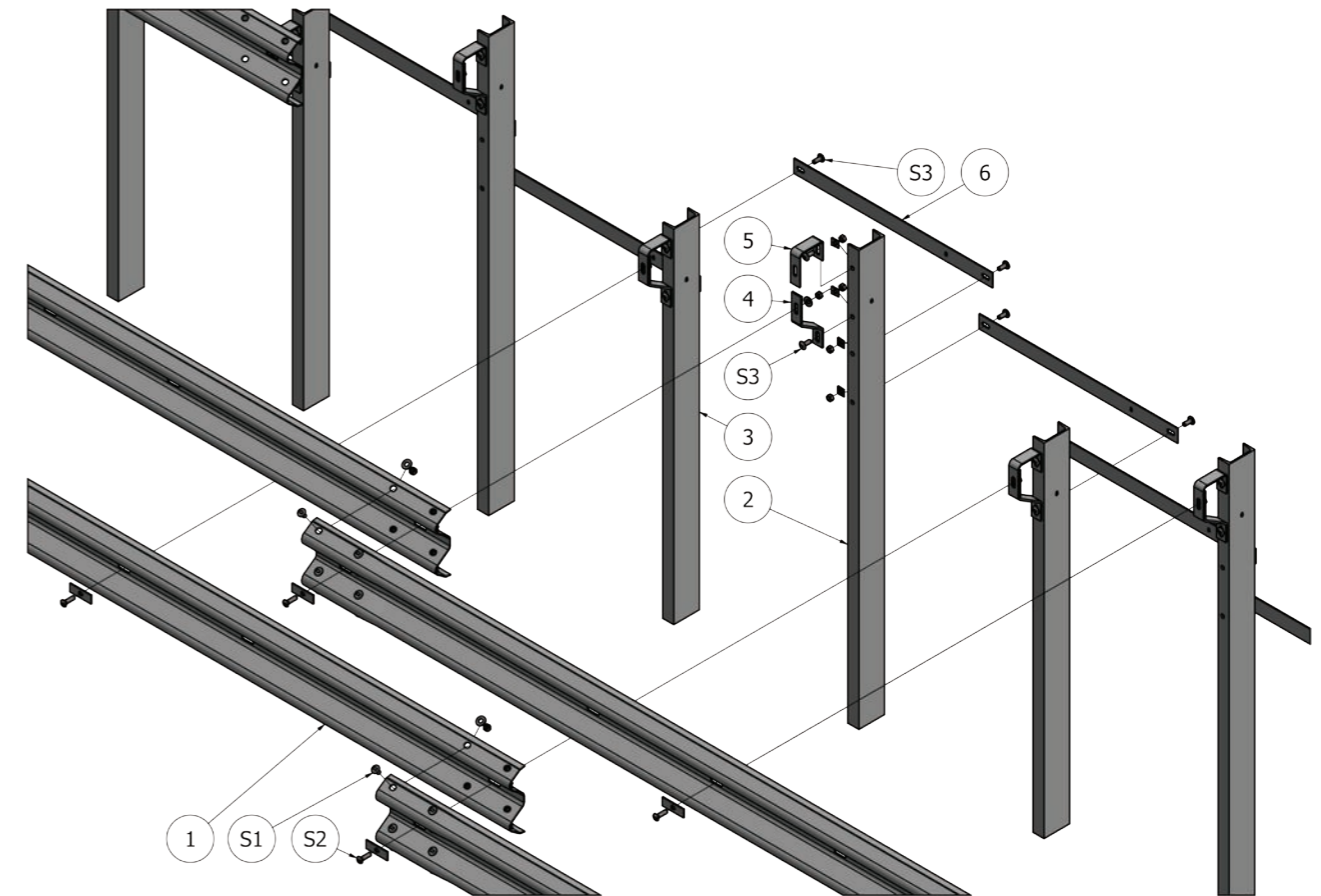

Název dílu	Pozice Position	Číslo dílu Component No.	Ks/4m Pcs/4m	Designation
Šroub s polokruhovou hl. a oválem M16x30-5.8-tZn	S1	40.03	16	Cup oval neck bolt M16x30 - 5.8 - tZn
Maticice M 16-6-tZn		59.2.40	16	Nut M16-6-tZn ISO 4032
Podložka 18-tZn (ø 19/40/4)		59.4.41	16	Washer 18-tZn (ø 19/40/4)
Šroub s polokruhovou hlavou a nosem M16x55-4.6-tZn	S2	59.0.82	4	Cup nib bolt M16x55-4.6-tZn
Maticice M 16-6-tZn		59.2.40	4	Nut M16-6-tZn ISO 4032
Podložka 18-tZn (ø 19/40/4)		59.4.41	4	Washer 18-tZn (ø 19/40/4)
Krycí podložka M16		59.4.80	4	Backplate M16
Šroub s polokruhovou hl. a oválem M16x40-5.8-tZn	S3	59.0.90	16	Cup oval neck bolt M16x40 - 5.8 - tZn
Maticice M 16-6-tZn		59.2.40	16	Nut M16-6-tZn ISO 4032
U-podložka 18-tZn (klínová)		59.4.72	16	U washer 18-tZn (taper washer)

# Jednostranné svodidlo Single-sided safety barrier



## J4A-1/H3-1

Zadržný systém byl testován a certifikován podle řady norem EN 1317.

Všechny díly jsou žárově zinkovány podle EN ISO 1461:2009

Restraint system was tested and certified in accordance with the standards EN 1317.

All parts are hot dip galvanized in accordance with the EN ISO 1461:2009



1020  
Liberty Ostrava a.s.  
Vratimovská 689  
707 02 Ostrava-Kunčice, Czech Republic  
Tel: +(420) 595 681 111

20  
Číslo: 1020-CPR-090-046394  
EN 1317-5:2007+A2:2012/AC:2012

Výrobek: Silniční záchytný systém  
Varianta: Ocelové silniční svodidlo jednostranné  
J4A-1/H3-1

Trvanlivost:	Uvedeno v Prohlášení o vlastnostech
Úroveň zadržení:	
Prudkost nárazu:	
Pracovní šířka:	č. LO/1/2020/CZ
Dynamický průhyb:	
Vychýlení vozidla:	

Nebezpečné vlastnosti:

Úroveň zadržení  
Containment level

# H3

Test EN 1317



TB 11 900 kg; 100 km/h



TB 61 16 000 kg; 80 km/h

Hmotnost systému  
System weight

# 73,14 kg/m

Odolnost svodidla proti odklizení sněhu  
Resistance to snow removal

# 4

Index prudkosti nárazu  
Acceleration severity index

# B

ASI = 1,4

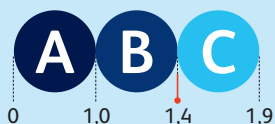

Pracovní šířka  
Working width

# W6

W=1,9 m, D=1,8 m



Liberty Ostrava a.s.,  
Vratimovská 689/117  
719 00 Ostrava-Kunčice  
Czech Republic

T +420 595 684 700  
+420 595 685 627  
+420 595 684 590

E tomas.hamalcik@libertysteelgroup.com

W [libertysteelgroup.com/cz/](http://libertysteelgroup.com/cz/)  
[libertysteelgroup.com](http://libertysteelgroup.com)