



LIBERTY

MEMBER OF



Oboustranné svodidlo s patní deskou
Double-sided safety barrier with foot plate

OSP NH4/H2

May 2021

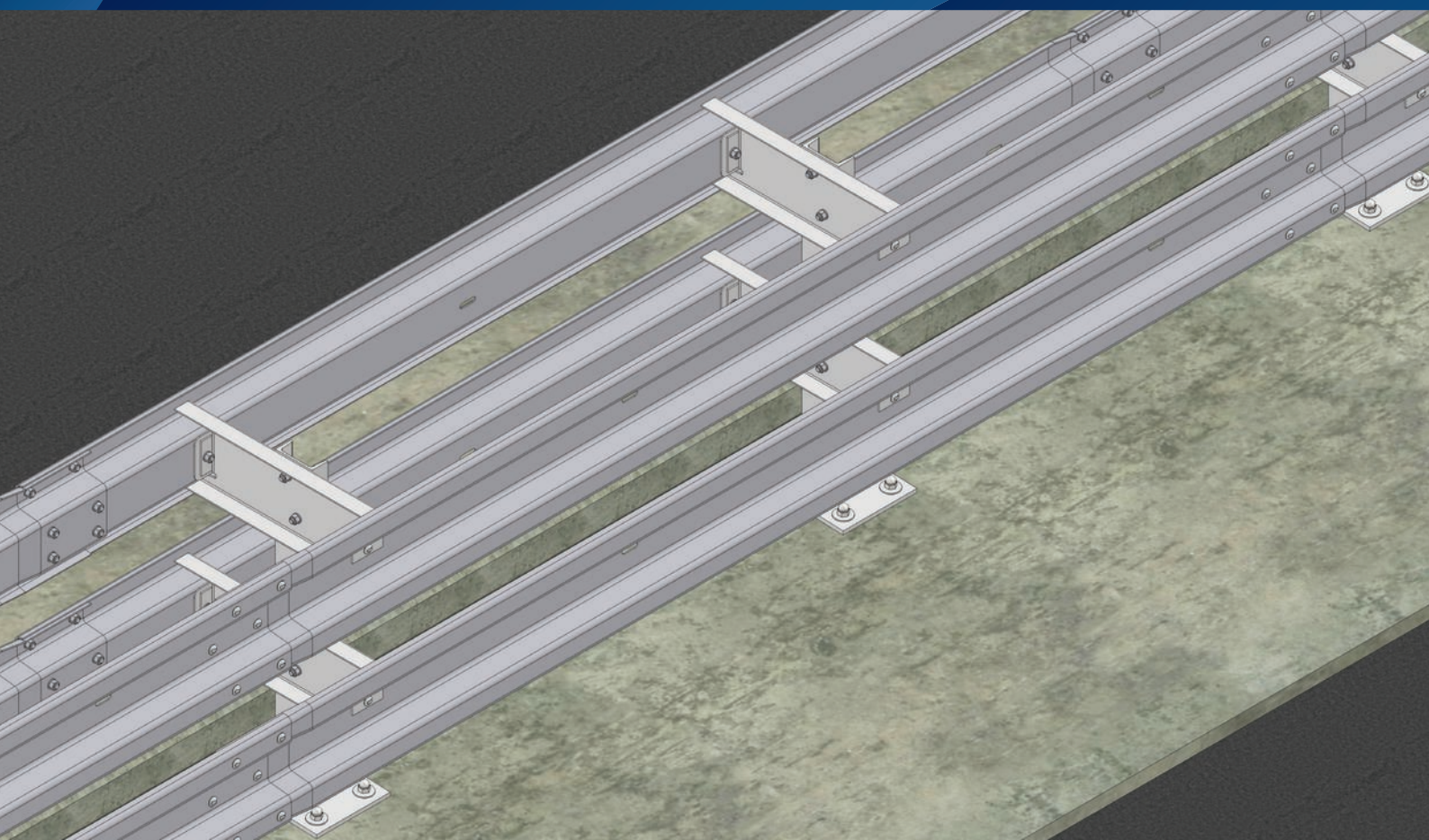

Úroveň zadržení
Containment level

H2

Index prudkosti nárazu
Acceleration severity index

B

Pracovní šířka
Working width

W5

Hmotnost systému
System weight

98 kg/m

Oboustranné svodidlo s patní deskou
Double-sided safety barrier with foot plate



OSPNH4/H2

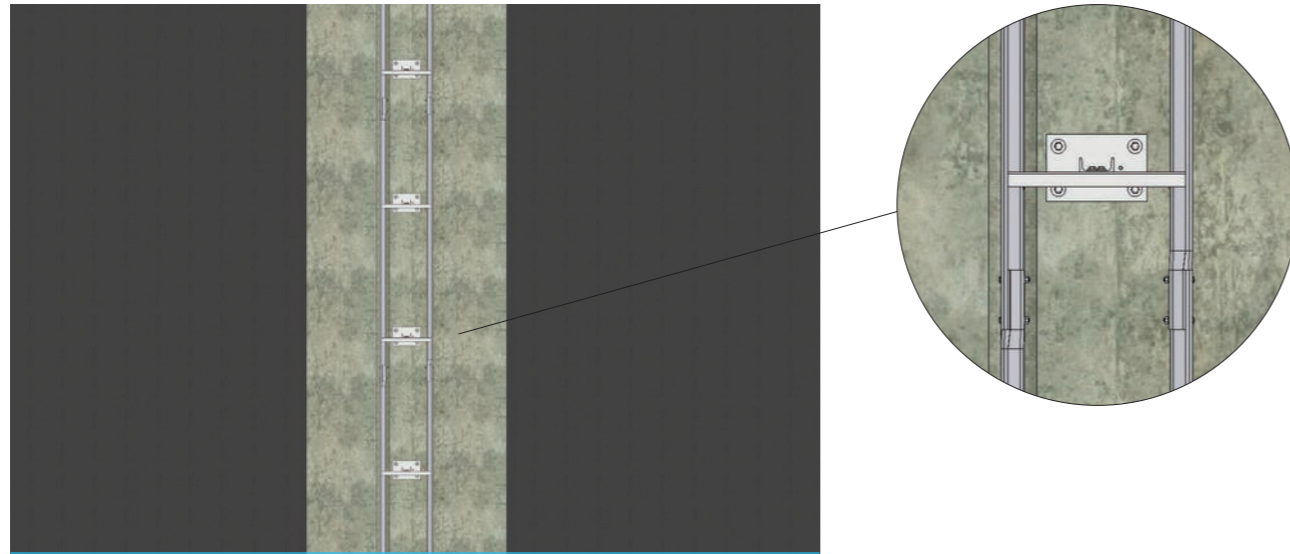

Název dílu	Pozice Position	Materiál Material	Číslo dílu Component No.	Ks/4m Pcs/4m	Designation
Svodnice NH4	1	S235JR	50.0.00	4	Barrier strip NH4
Sloupek U140 střední s patní deskou	2	S235JR	51.4.21	2	Middle post U140 with foot plate
Distanční díl NH4 II	3	S235JR	52.0.03	4	Spacer NH4 II

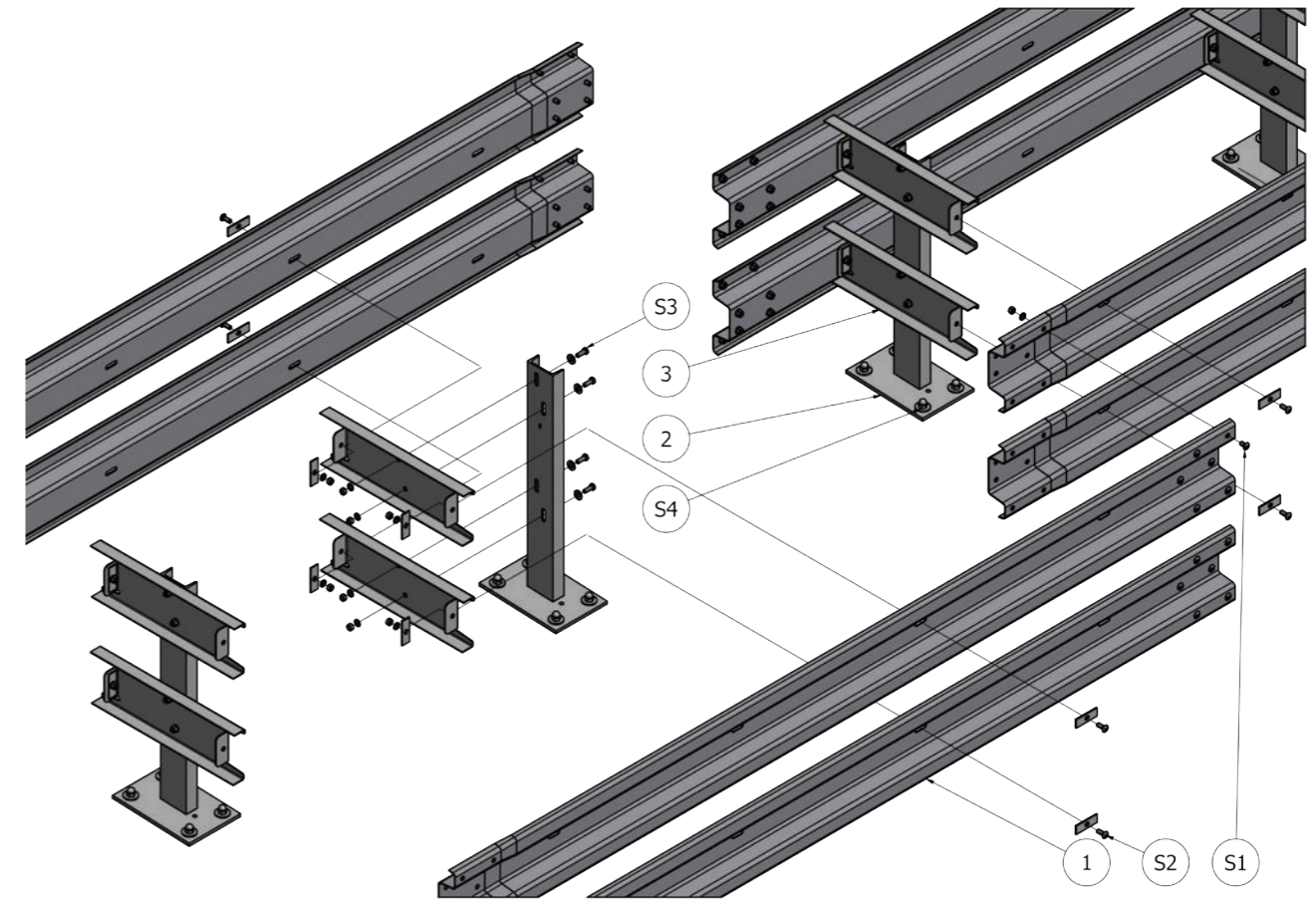
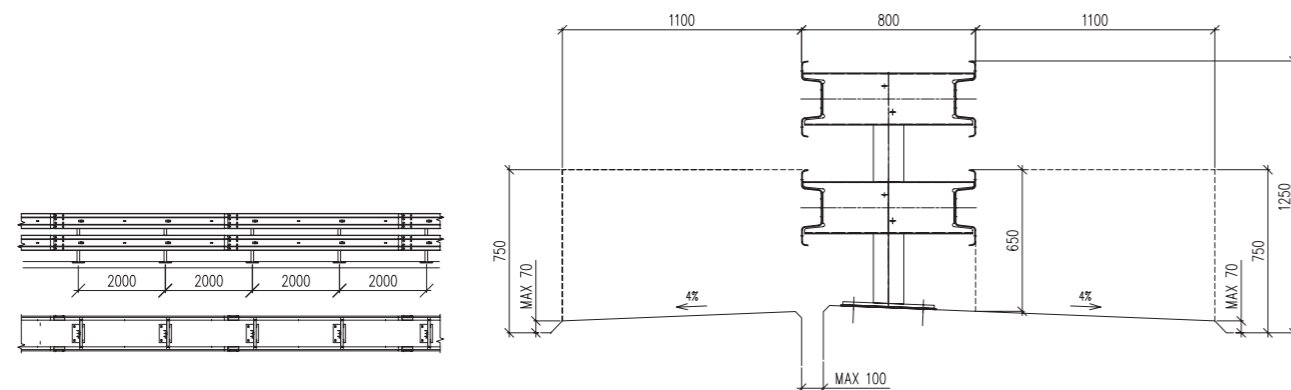

Název dílu	Pozice Position	Číslo dílu Component No.	Ks/4m Pcs/4m	Designation
Šroub s polokruhovou hlavou a nose M16x30-4.6-tZn	S1	59.0.80	32	Cup nib bolt M16x30-4.6-tZn
Matice M 16-6-tZn		59.2.40	32	Nut M16-6-tZn ISO 4032
Podložka 17,5-tZn (ø 17,5/30/3)		59.4.40	32	Washer 17.5-tZn (ø 17,5/30/3)
Šroub s polokruhovou hlavou a nose M16x40-4.6-tZn	S2	59.0.81	8	Cup nib bolt M16x40-4.6-tZn
Matice M 16-6-tZn		59.2.40	8	Nut M16-6-tZn ISO 4032
Podložka 17,5-tZn (ø 17,5/30/3)		59.4.40	8	Washer 17.5-tZn (ø 17,5/30/3)
Krycí podložka M16		59.4.80	16	Backplate M16
Šroub se šestihrannou hlavou M16x40- 8.8-tZn	S3	59.0.44	8	Hexagonal bolt M16x40-8.8-tZn
Matice M 16-8.8-tZn		59.2.41	8	Nut M16-8.8-tZn ISO 4032
Podložka 17,5-tZn (ø 17,5/30/3)		59.4.40	8	Washer 17.5-tZn (ø 17,5/30/3)
Podložka 18-tZn (ø 19/40/4)		59.4.41	8	Washer 18-tZn (ø 19/40/4)
Kotva M20	S4		8	Anchor M20 or Anchor rod M20

Oboustranné svodidlo s patní deskou Double-sided safety barrier with foot plate



OSPNH4/H2

Zadržný systém byl testován a certifikován podle řady norem EN 1317.

Všechny díly jsou žárově zinkovány podle EN ISO 1461:2009

Restraint system was tested and certified in accordance with the standards EN 1317.

All parts are hot dip galvanized in accordance with the EN ISO 1461:2009



1020

Liberty Ostrava a.s.
Vratimovská 689
707 02 Ostrava-Kunčice, Czech Republic
Tel: +(420) 595 681 111

19

Číslo: 1020-CPR-090-023770

EN 1317-5:2007+A2:2012/AC:2012

Výrobek: Silniční záchytný systém

Varianta: Ocelové silniční svodidlo jednostranné
OSPNH4/H2

Trvanlivost:	Uvedeno v Prohlášení o vlastnostech
Úroveň zadržení:	č. LO/30/2019/CZ
Prudkost nárazu:	
Pracovní šířka:	
Dynamický průhyb:	
Vychýlení vozidla:	

Nebezpečné vlastnosti:

Úroveň zadržení
Containment level

H2

Test EN 1317



TB 11 900 kg; 100 km/h



TB 51 13 000 kg; 70 km/h

Hmotnost systému
System weight

98 kg/m

Odolnost svodidla proti odklizení sněhu
Resistance to snow removal

4

Index prudkosti nárazu
Acceleration severity index

B

ASI = 1,319

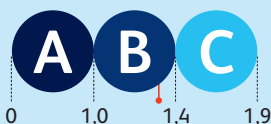

Pracovní šířka
Working width

W5

W=1,6 m, D=0,8 m



Liberty Ostrava a.s.,
Vratimovská 689/117
719 00 Ostrava-Kunčice
Czech Republic

T +420 595 684 700
+420 595 685 627
+420 595 684 590

E tomas.hamalcik@libersteeelgroup.com

W libersteeelgroup.com/cz/
libersteeelgroup.com