



LIBERTY

MEMBER OF



Oboustranné svodidlo Double-sided safety barrier

OSNH4/H2

May 2021

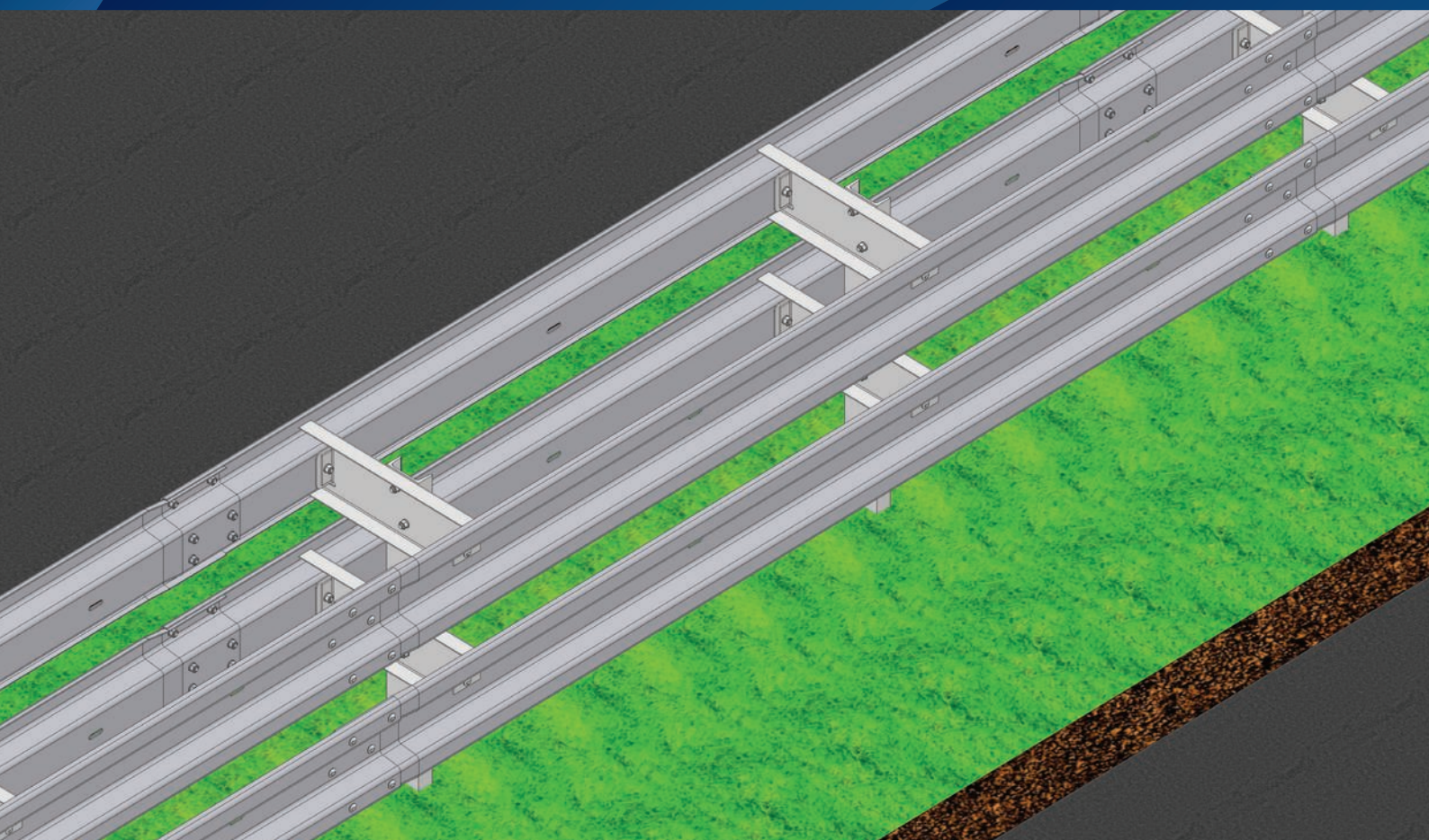

Úroveň zadržení
Containment level

H2

Index prudkosti nárazu
Acceleration severity index

B

Pracovní šířka
Working width

W5

Hmotnost systému
System weight

102,58 kg/m

Oboustranné svodidlo
Double-sided safety barrier



OSNH4/H2

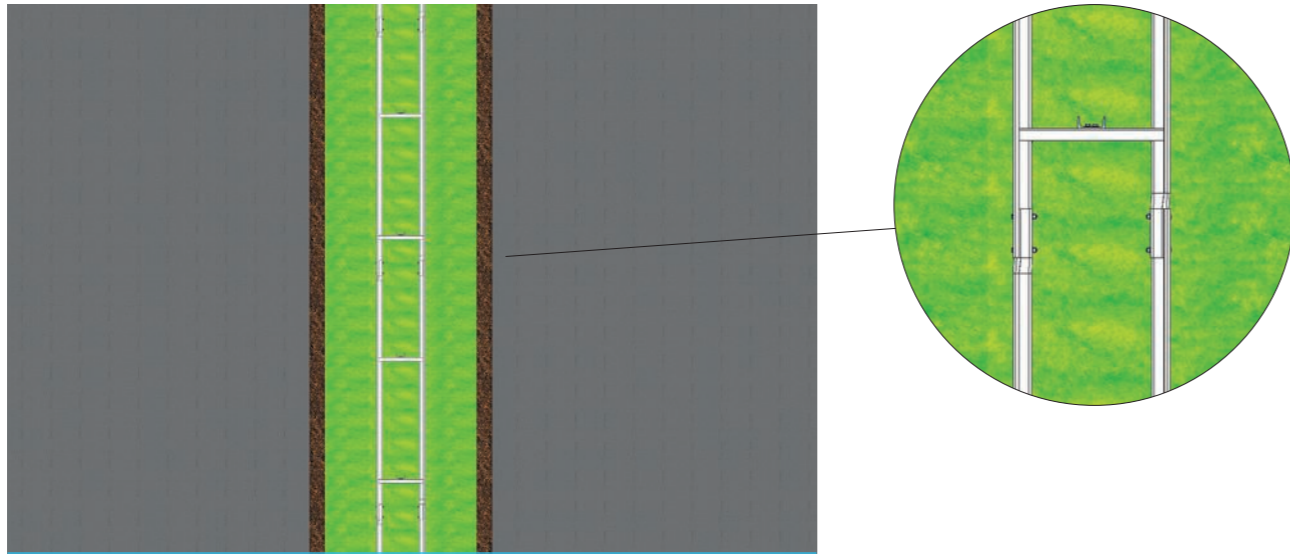

Název dílu	Pozice Position	Materiál Material	Číslo dílu Component No.	Ks/4m Pcs/4m	Designation
Svodnice NH4	1	S235JR	50.0.00	4	Barrier strip NH4
Sloupek U140 střední 2400	2	S235JR	51.1.10	2	Middle post U140 2400
Distanční díl NH4 II	3	S235JR	52.0.03	4	Spacer NH4 II

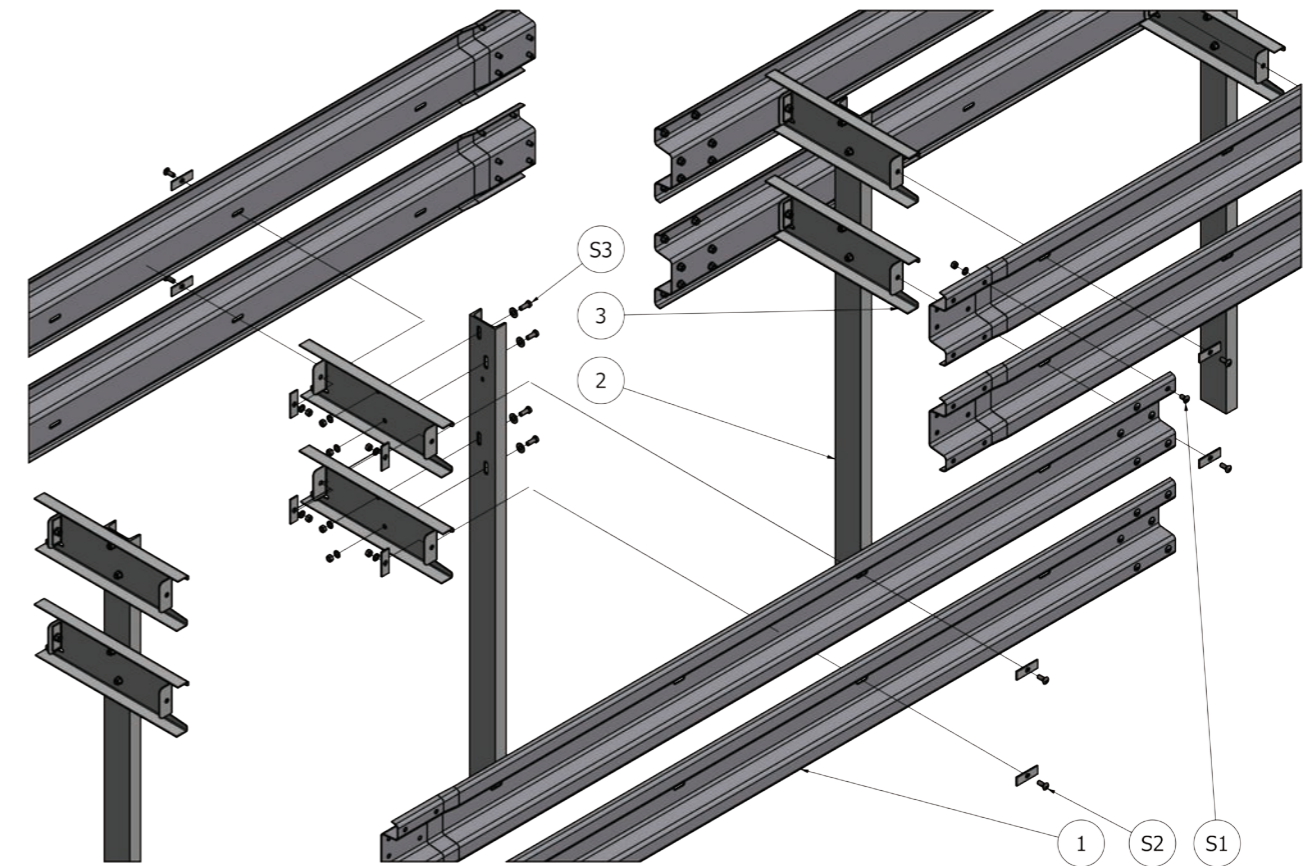
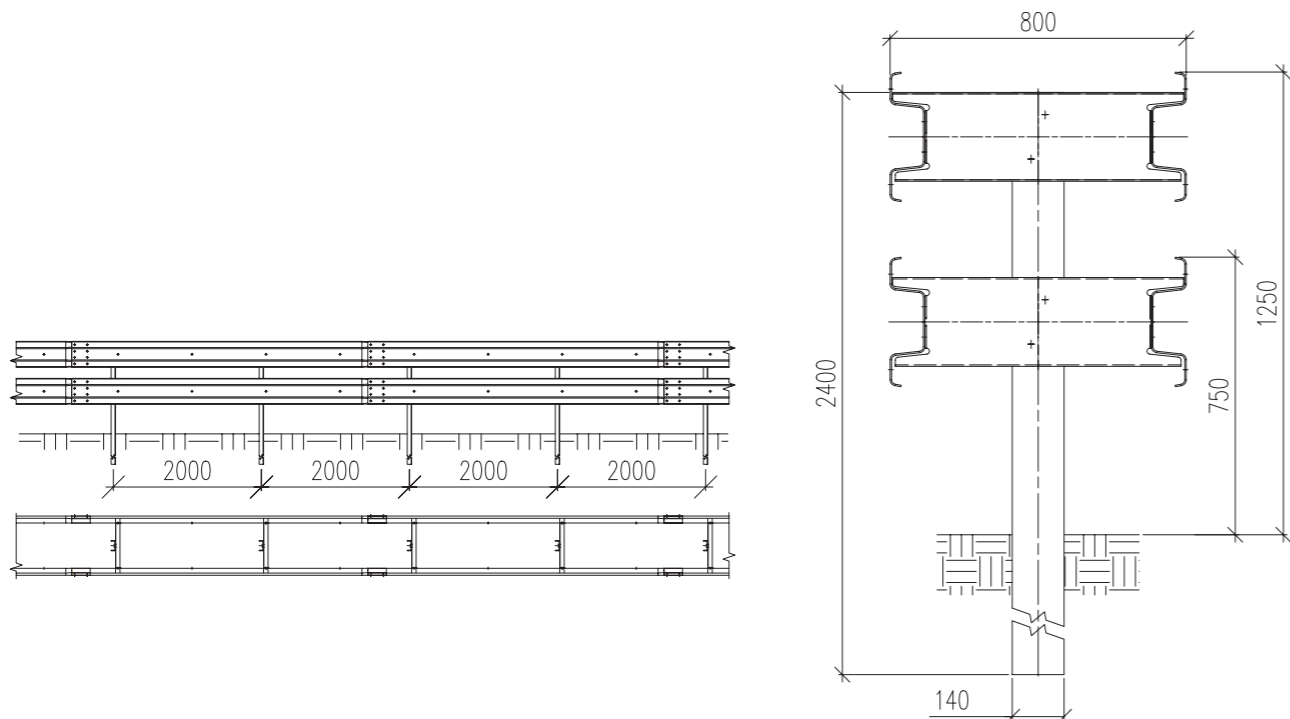

Název dílu	Pozice Position	Číslo dílu Component No.	Ks/4m Pcs/4m	Designation
Šroub s polokruhovou hlavou a nosem M16x30-4.6-tZn	S1	59.0.80	32	Cup nib bolt M16x30-4.6-tZn
Matice M 16-6-tZn		59.2.40	32	Nut M16-6-tZn ISO 4032
Podložka 17,5-tZn (ø 17,5/30/3)		59.4.40	32	Washer 17.5-tZn (ø 17,5/30/3)
Šroub s polokruhovou hlavou a nosem M16x40-4.6-tZn	S2	59.0.81	8	Cup nib bolt M16x40-4.6-tZn
Matice M 16-6-tZn		59.2.40	8	Nut M16-6-tZn ISO 4032
Podložka 17,5-tZn (ø 17,5/30/3)		59.4.40	8	Washer 17.5-tZn (ø 17,5/30/3)
Krycí podložka M16		59.4.80	16	Backplate M16
Šroub se šestihlannou hlavou M16x40-8.8-tZn	S3	59.0.44	8	Hexagonal bolt M16x40-8.8-tZn
Matice M 16-8.8-tZn		59.2.41	8	Nut M16-8.8-tZn ISO 4032
Podložka 17,5-tZn (ø 17,5/30/3)		59.4.40	8	Washer 17.5-tZn (ø 17,5/30/3)
Podložka 18-tZn (ø 19/40/4)		59.4.41	8	Washer 18-tZn (ø 19/40/4)

Oboustranné svodidlo Double-sided safety barrier



OSNH4/H2

Zadržný systém byl testován a certifikován podle řady norem EN 1317.

Všechny díly jsou žárově zinkovány podle EN ISO 1461:2009

Restraint system was tested and certified in accordance with the standards EN 1317.

All parts are hot dip galvanized in accordance with the EN ISO 1461:2009



1020

Liberty Ostrava a.s.
Vratimovská 689
707 02 Ostrava-Kunčice, Czech Republic
Tel: +(420) 595 681 111

19

Číslo: 1020-CPR-090-023768
EN 1317-5:2007+A2:2012/AC:2012

Výrobek: Silniční záchytný systém
Varianta: Ocelové silniční svodidlo oboustranné
OSNH4/H2

Trvanlivost:	Uvedeno v Prohlášení o vlastnostech
Úroveň zadržení:	
Prudkost nárazu:	č. LO/29/2019/CZ
Dynamický průhyb:	
Vychýlení vozidla:	

Nebezpečné vlastnosti:

Úroveň zadržení
Containment level

H2

Test EN 1317



TB 11 900 kg; 100 km/h



TB 51 13 000 kg; 70 km/h

Hmotnost systému
System weight

102,58 kg/m

Odolnost svodidla proti odklízení sněhu
Resistance to snow removal

4

Index prudkosti nárazu
Acceleration severity index

B

ASI = 1,319

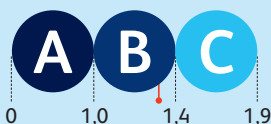

Pracovní šířka
Working width

W5

W=1,6 m, D=0,8 m



Liberty Ostrava a.s.,
Vratimovská 689/117
719 00 Ostrava-Kunčice
Czech Republic

T +420 595 684 700
+420 595 685 627
+420 595 684 590

E tomas.hamalcik@libertysteelgroup.com

W libertysteelgroup.com/cz/
libertysteelgroup.com