



LIBERTY

MEMBER OF



Oboustranné svodidlo s patní deskou Double-sided safety barrier with foot plate

OP3A-1,3/H2-1

May 2021

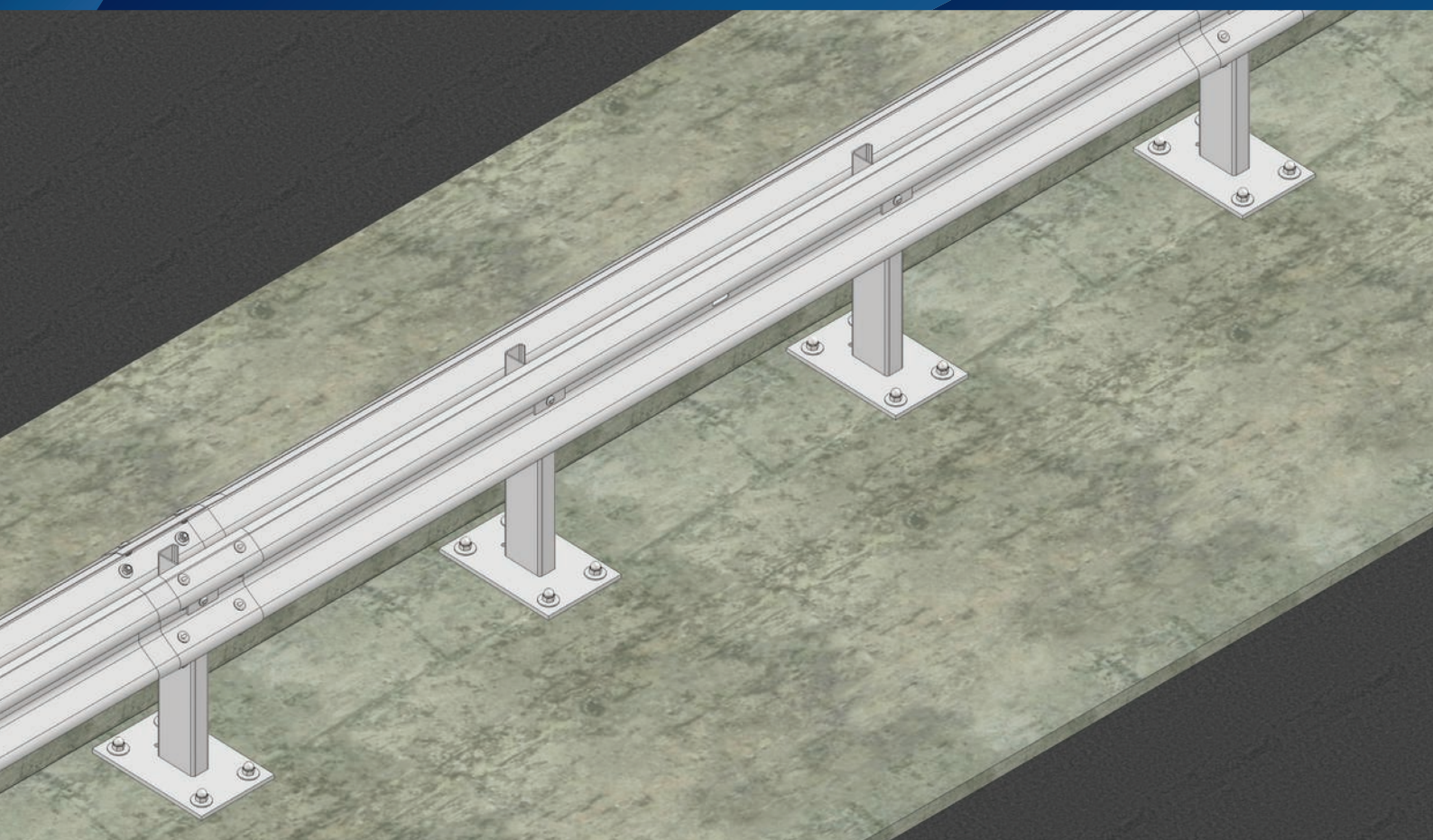

Úroveň zadržení
Containment level

H2

Index prudkosti nárazu
Acceleration severity index

A

Pracovní šířka
Working width

W3

Hmotnost systému
System weight

40,71 kg/m

Oboustranné svodidlo s patní deskou
Double-sided safety barrier with foot plate



OP3A-1,3/H2-1

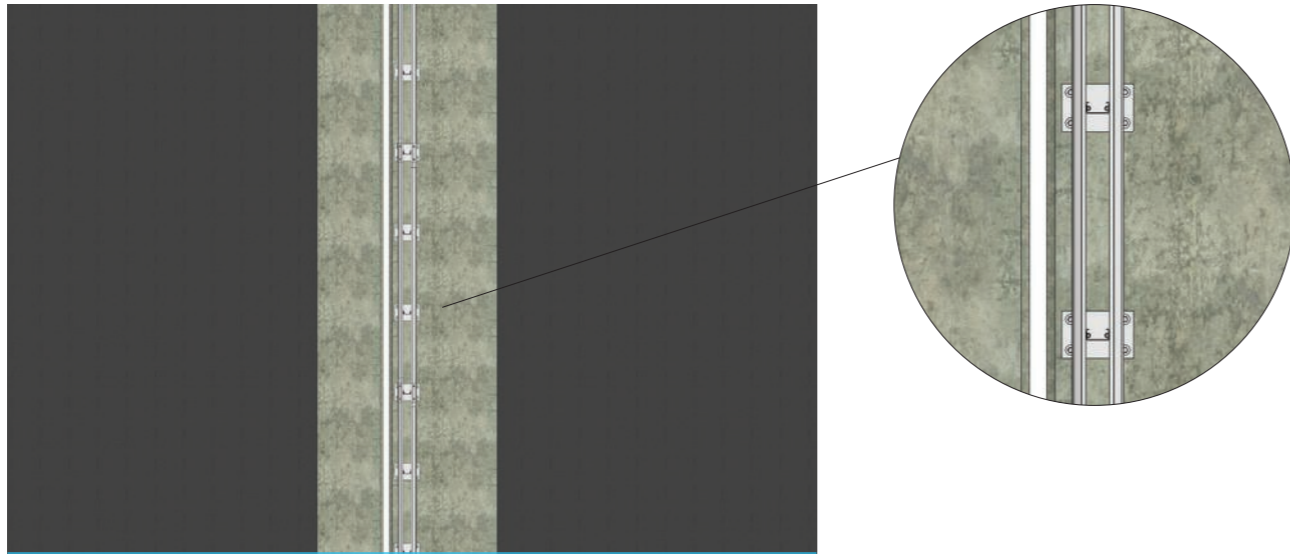

Název dílu	Pozice Position	Materiál Material	Číslo dílu Component No.	Ks/4m Pcs/4m	Designation
Svodnice A-NH-94/N	1	S235JR	1.00	2	Barrier strip A-NH-94/N
Sloupek C140 střední A-H2 s patní deskou alfa*	2	S235JR	71.4.00	3	Middle post C140 A-H2 with foot plate ALFA %

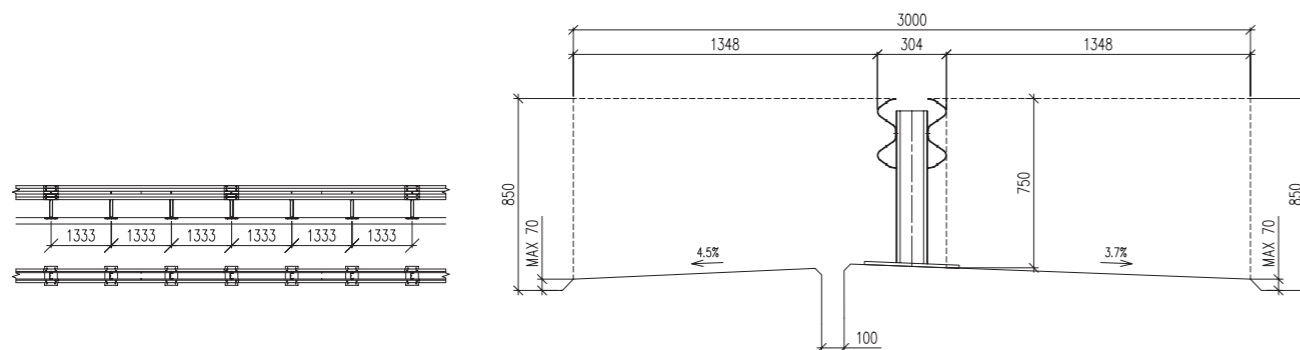
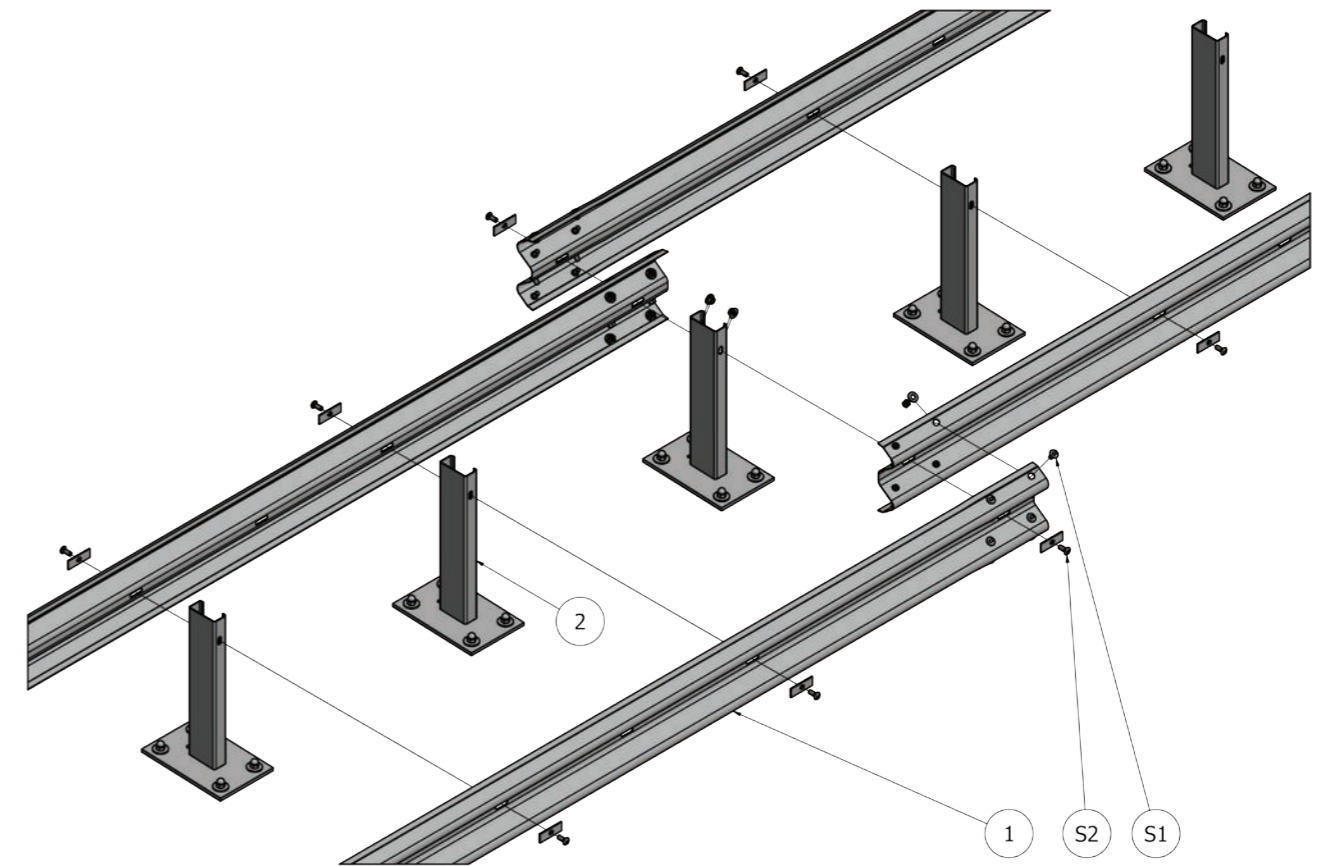

Název dílu	Pozice Position	Číslo dílu Component No.	Ks/4m Pcs/4m	Designation
Šroub s polokružovou hl. a oválem M16x30-5.8-tZn	S1	40.03	16	Cup oval neck bolt M16x30 - 5.8 - tZn
Matice M 16-6-tZn		59.2.40	16	Nut M16-6-tZn ISO 4032
Podložka 18-tZn (ø 19/40/4)		59.4.41	16	Washer 18-tZn (ø 19/40/4)
Šroub s polokružovou hlavou a nosem M16x40-4.6-tZn	S2	59.0.81	6	Cup nib bolt M16x40-4.6-tZn
Matice M 16-6-tZn		59.2.40	6	Nut M16-6-tZn ISO 4032
Podložka 18-tZn (ø 19/40/4)		59.4.41	6	Washer 18-tZn (ø 19/40/4)
Krycí podložka M16	S3	59.4.80	6	Backplate M16
Kotva M20			12	Anchor M20 or Anchor rod M20

Oboustranné svodidlo s patní deskou Double-sided safety barrier with foot plate



OP3A-1,3/H2-1

Zadržný systém byl testován a certifikován podle řady norem EN 1317.

Všechny díly jsou žárově zinkovány podle EN ISO 1461:2009

Restraint system was tested and certified in accordance with the standards EN 1317.

All parts are hot dip galvanized in accordance with the EN ISO 1461:2009



1020

Liberty Ostrava a.s.
Vratimovská 689
707 02 Ostrava-Kunčice, Czech Republic
Tel: +(420) 595 681 111

21

Číslo: 1020-CPR-090-051787

EN 1317-5:2007+A2:2012/AC:2012

Výrobek: Siličnický záchytný systém

Varianta: Ocelové siličnické svodidlo jednostranné

OP3A-1,3/H2-1

Trvanlivost:	Úroveň zadržení:	Uvedeno v Prohlášení o vlastnostech č. 10/2/2021/CZ
Prudkost nárazu:	Pracovní šířka:	
Dynamický průhyb:	Vychýlení vozidla:	
Vychýlení vozidla:		

Nebezpečné vlastnosti:

Úroveň zadržení
Containment level

H2

Test EN 1317



TB 11 900 kg; 100 km/h



TB 51 13 000 kg; 70 km/h

Hmotnost systému
System weight

40,71 kg/m

Odolnost svodidla proti odklizení sněhu
Resistance to snow removal

3

Index prudkosti nárazu
Acceleration severity index

A

ASI = 0,9

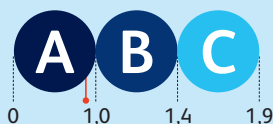

Pracovní šířka
Working width

W3

W=1 m, D=0,8 m



Liberty Ostrava a.s.,
Vratimovská 689/117
719 00 Ostrava-Kunčice
Czech Republic

T +420 595 684 700
+420 595 685 627
+420 595 684 590

E tomas.hamalcik@libertysteelgroup.com

W libertysteelgroup.com/cz/
libertysteelgroup.com