



LIBERTY

MEMBER OF



Jednostranné svodidlo Single-sided safety barrier

JSNH4/H1

May 2021

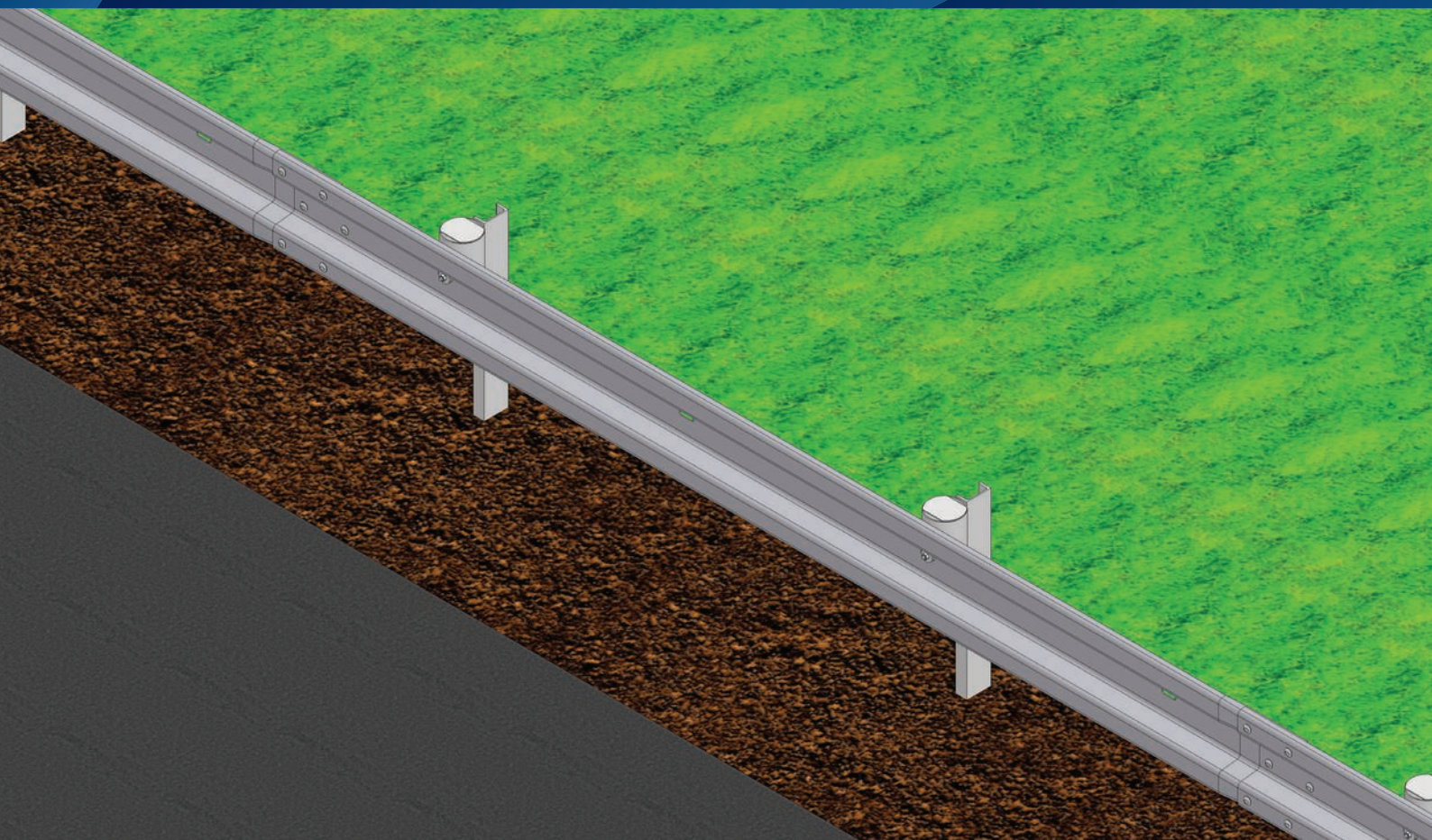

Úroveň zadržení
Containment level

H1

Index prudkosti nárazu
Acceleration severity index

A

Pracovní šířka
Working width

W5

Hmotnost systému
System weight

28,09 kg/m

Jednostranné svodidlo
Single-sided safety barrier

JSNH4/H1

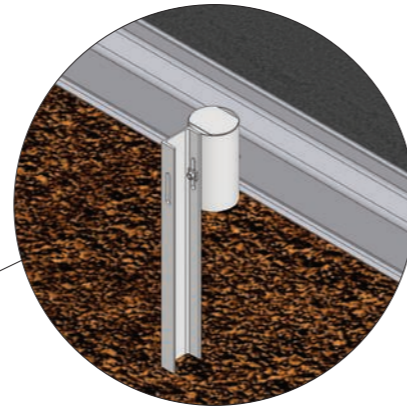
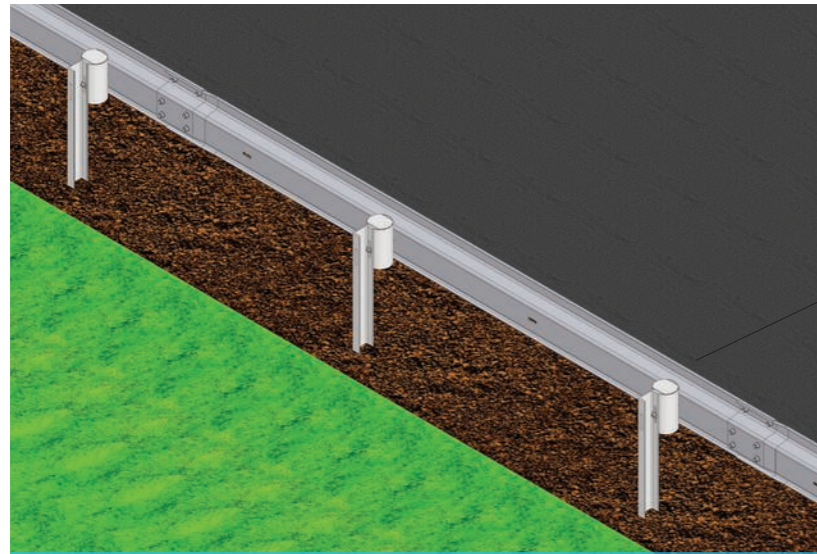

Název dílu	Pozice Position	Materiál Material	Číslo dílu Component No.	Ks/4m Pcs/4m	Designation
Svodnice NH4	1	S235JR	50.0.00	1	Barrier strip NH4
Sloupek UE100 krajní 1900	2	S235JR	51.0.00	2	Outer post UE100 1900
Trubková spojka	3	S23JRH+JR	52.0.00	2	Tube joint

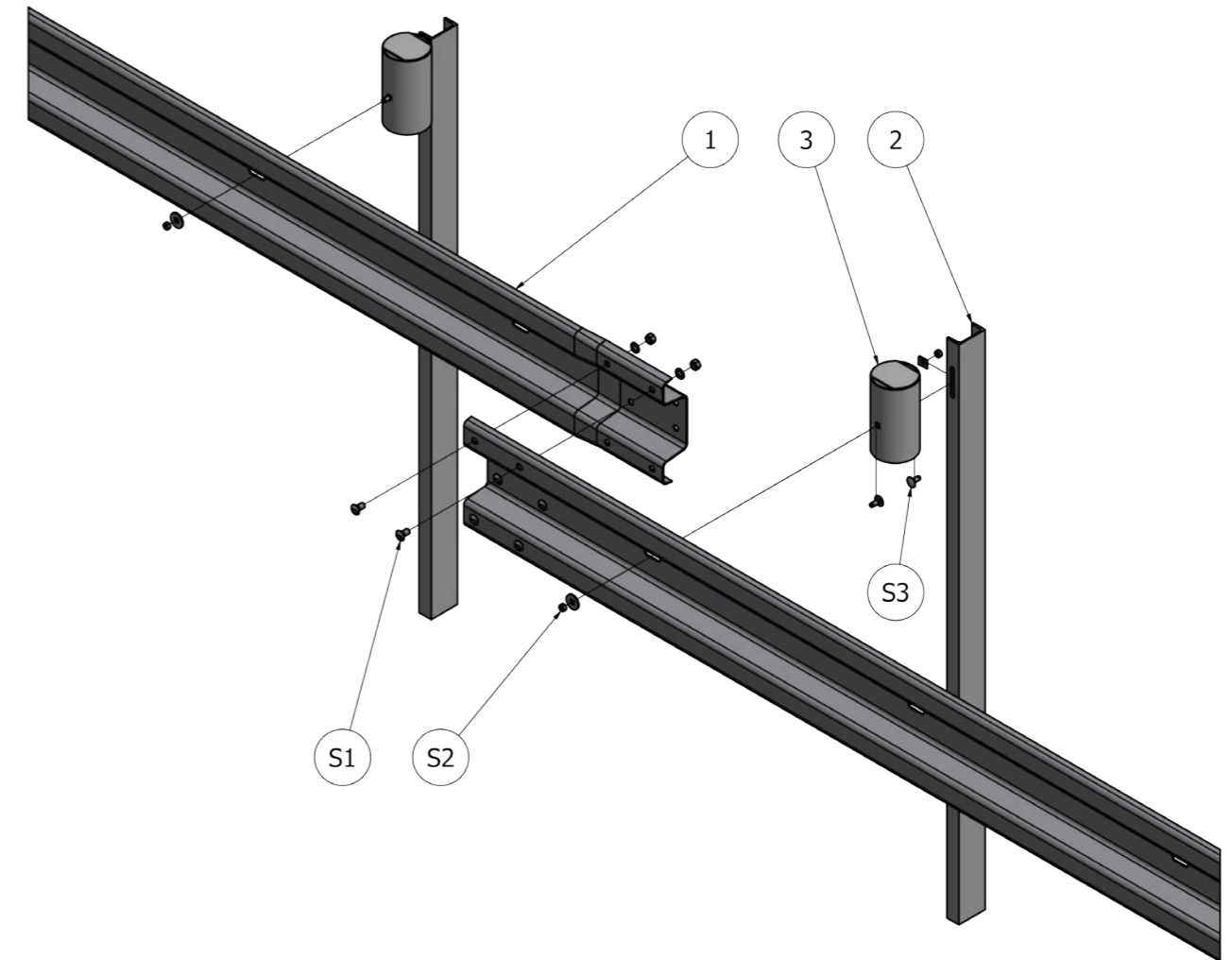
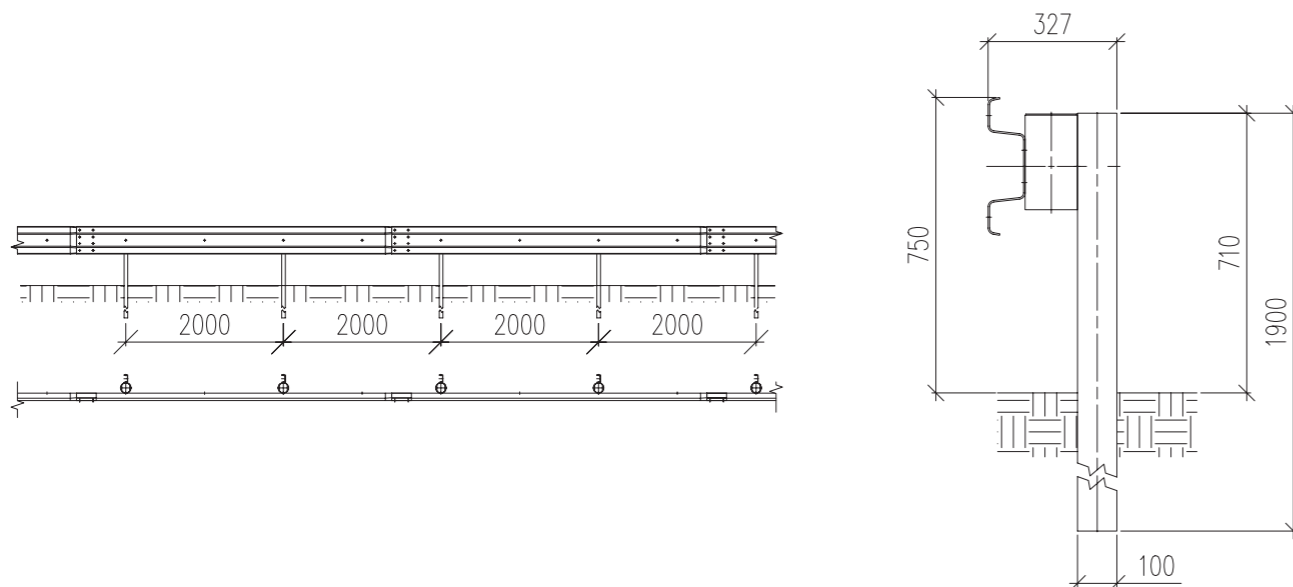

Název dílu	Pozice Position	Číslo dílu Component No.	Ks/4m Pcs/4m	Designation
Šroub s polokruhovou hlavou a nosem M16x30-4.6-tZn	S1	59.0.80	8	Cup nib bolt M16x30-4.6-tZn
Matice M 16-6-tZn		59.2.40	8	Nut M16-6-tZn ISO 4032
Podložka 17,5-tZn (ø 17,5/30/3)		59.4.40	8	Washer 17.5-tZn (ø 17,5/30/3)
Šroub s polokruhovou hlavou a čtyřhranem M12x30-4.6-tZn	S2	59.0.70	2	Cup square neck bolt M12x30-4.6-tZn
Matice M 12-6-tZn		59.2.20	2	Nut M12-6-tZn ISO 4032
Podložka 14-tZn (14/ø 44/4-otvor 4HR)		59.4.70	2	Washer 14-tZn (ø 14/44/4-is a square hole)
Šroub s polokruhovou hlavou a čtyřhranem M12x30-4.6-tZn	S3	59.0.70	2	Cup square neck bolt M12x30-4.6-tZn
Matice M 12-6-tZn		59.2.20	2	Nut M12-6-tZn ISO 4032
U-podložka 14-tZn (klínová)		59.4.71	2	U washer 14-tZn (taper washer)

Jednostranné svodidlo Single-sided safety barrier



JSNH4/H1

Zadržný systém byl testován a certifikován podle řady norem EN 1317.

Všechny díly jsou žárově zinkovány podle EN ISO 1461:2009

Restraint system was tested and certified in accordance with the standards EN 1317.

All parts are hot dip galvanized in accordance with the EN ISO 1461:2009



1020
Liberty Ostrava a.s.
Vratimovská 689
707 02 Ostrava-Kunčice, Czech Republic
Tel: +(420) 595 681 111

19
Číslo: 1020-CPR-090-024818
EN 1317-5:2007+A2:2012/AC:2012

Výrobek: Silniční zadržný systém
Varianta: Ocelové silniční svodidlo jednostranné
JSNH4/H1

Trvanlivost:	Uvedeno v Prohlášení o vlastnostech
Úroveň zadržení:	
Prudkost nárazu:	č. 10/9/2019/CZ
Pracovní šířka:	
Dynamický průhyb:	
Vychýlení vozidla:	

Nebezpečné vlastnosti:

Úroveň zadržení
Containment level

H1

Test EN 1317



TB 11 900 kg; 100 km/h



TB 42 10 000 kg; 70 km/h

Hmotnost systému
System weight

28,09 kg/m

Odolnost svodidla proti odklizení sněhu
Resistance to snow removal

4

Index prudkosti nárazu
Acceleration severity index

A

ASI = 0,925

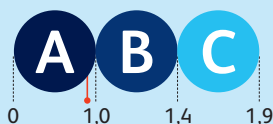

Pracovní šířka
Working width

W5

W=1,53 m, D=1,2 m



Liberty Ostrava a.s.,
Vratimovská 689/117
719 00 Ostrava-Kunčice
Czech Republic

T +420 595 684 700
+420 595 685 627
+420 595 684 590

E tomas.hamalcik@libertysteelgroup.com

W libertysteelgroup.com/cz/
libertysteelgroup.com