

Cold-Formed Steel Open Profiles

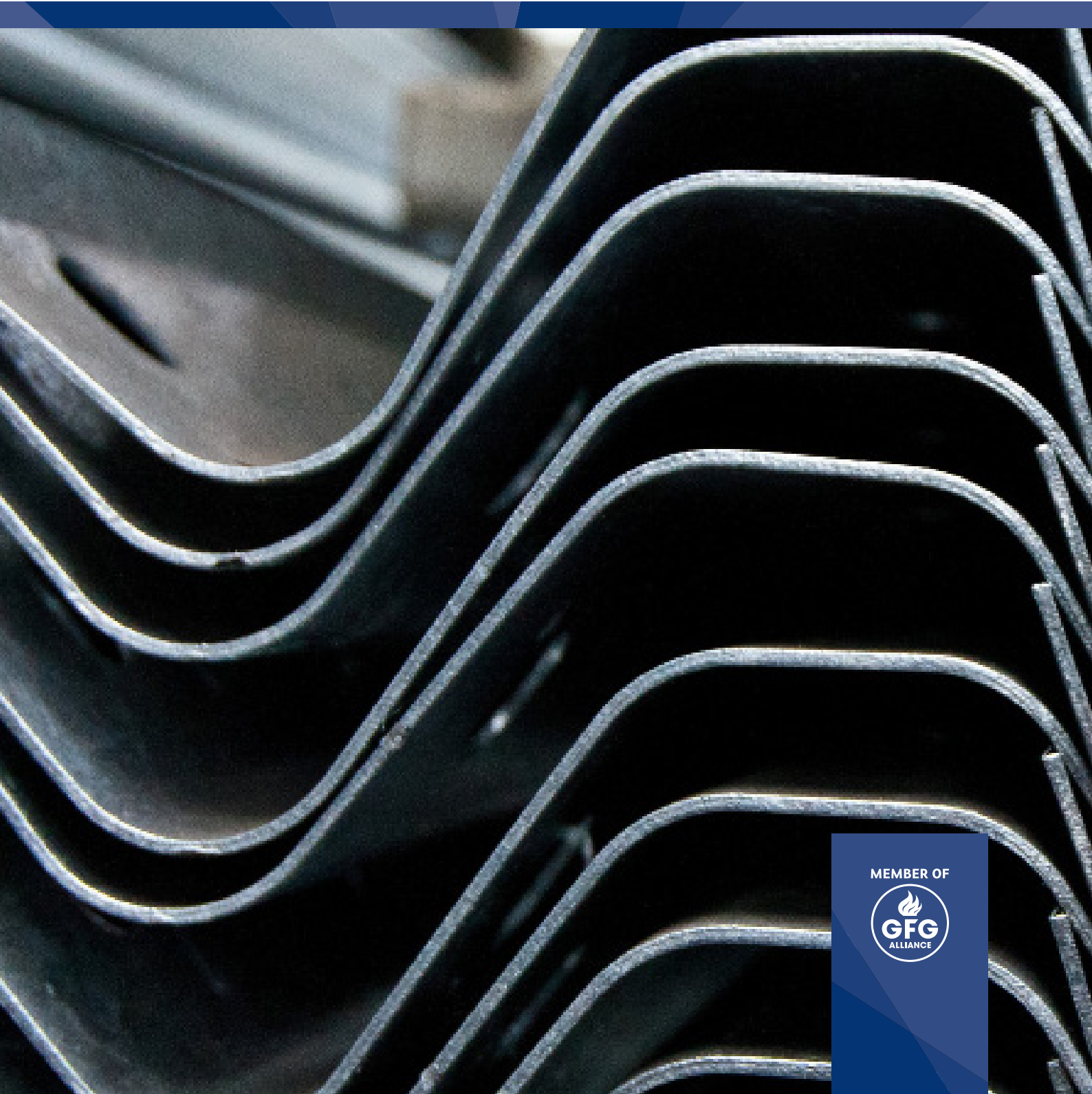

LIBERTY Ostrava
www.libertysteelgroup.com



MEMBER OF



Liberty Ostrava a.s. is an established Czech manufacturer of steel open profiles which are manufactured from hot-rolled strips at profiling lines.

Light-gauge steel open profiles, which are cold-formed by sequential profiling of the steel strip, are used to a great extent in many branches of industry including the building industry. Use of the profiles is appropriate especially where reduction of weight is desired by which reduction of production costs will be achieved at the same time in sufficient strength and stiffness. Visual aspects of the final product may also be the reason for use of the profiles.

The basic offer of steel open profiles includes the U-profiles, C-profiles, and the casing profile.

Extended offer includes profiles suitable for manufacture of steel road barriers and their accessories, the Z-profile, the sleeper profile, the gate profile, and the omega profile.

Available production facilities also enable manufacture of profiles of shapes and dimensions differing from those given in the basic and extended offers. However, considering the nature of the production facilities batch or bulk production would be insisted on.

We are ready to discuss, suggest and make changes or introduce manufacture of light-gauge steel open profiles of new shapes in conformity to customer's requirements.

Grades and standards

Dimension standards, technical and delivery regulations

Cold-formed steel open U and L-profiles are manufactured and delivered in conformity to the following dimension standards and technical and delivery regulations:

DIN EN 10162:2003 (DIN 59413:1976 and DIN 17118:1976)

CSN EN 10162:2004 (CSN 42 6963:1988 and CSN 42 0121:1975)

The remaining steel profiles are manufactured and delivered in conformity to the technical and delivery regulations of Liberty Ostrava a.s.



Basic offer of steel grades suitable for manufacture of steel open profiles

Steel open profiles are manufactured primarily from hot-rolled strips of structural steel grades with minimum yield point 235 MPa.

Steel open profiles from high-strength and micro-alloyed steel can be manufactured by agreement, depending on the desired quantity and size of the starting material (i.e. developed width of the profile required).

Structural Steel	EN 10025-2; DIN 17100	S235JR, S235JO; St 37-2, RSt 37-2, St 37-3
Structural high-strength steel	EN 10025-2; DIN 17100	S275JR, S275JO; St 44-2, St 44-3
Micro-alloyed steel	SEW 092; EN 10149-2	QStE 340 TM, QStE 380 TM; S315MC, S355MC, S420MC

Grades and standards continued...

Method of Delivery

The cutting of steel open profiles to desired length is performed by using a saw or shear die. The profiles can be supplied in production lengths, precise lengths or multiples of precise lengths ranging from 4.0 m to 12.0 m. Unless the customer specifies desired lengths, the profiles shall be supplied in production lengths.

The profiles are supplied in packs of maximum weight 5 t bound with a binding wire of 5.5mm. The packs are provided with identification labels. Number of cross bindings is 2 (for min. lengths) and 4 (for max. lengths).

Certifications and declarations of conformity

Certificate	Certification Body
Quality Management System in the branch	RW TÜV München
Environmental Management System in the branch	RW TÜV München
Light-gauge open profiles (equal angle U profiles)	TZÚS Praha
Light-gauge open profiles: C profile, Casing profile, Gate profile	TZÚS Praha
Light-gauge open profiles: sigma profile 100, C-profile 120x65	TZÚS Praha
Light-gauge open profiles: cross drain profile	TZÚS Praha

Attests

Attest in conformity to CSN EN 10204:1994 of the material delivered shall be sent to the customer upon request.

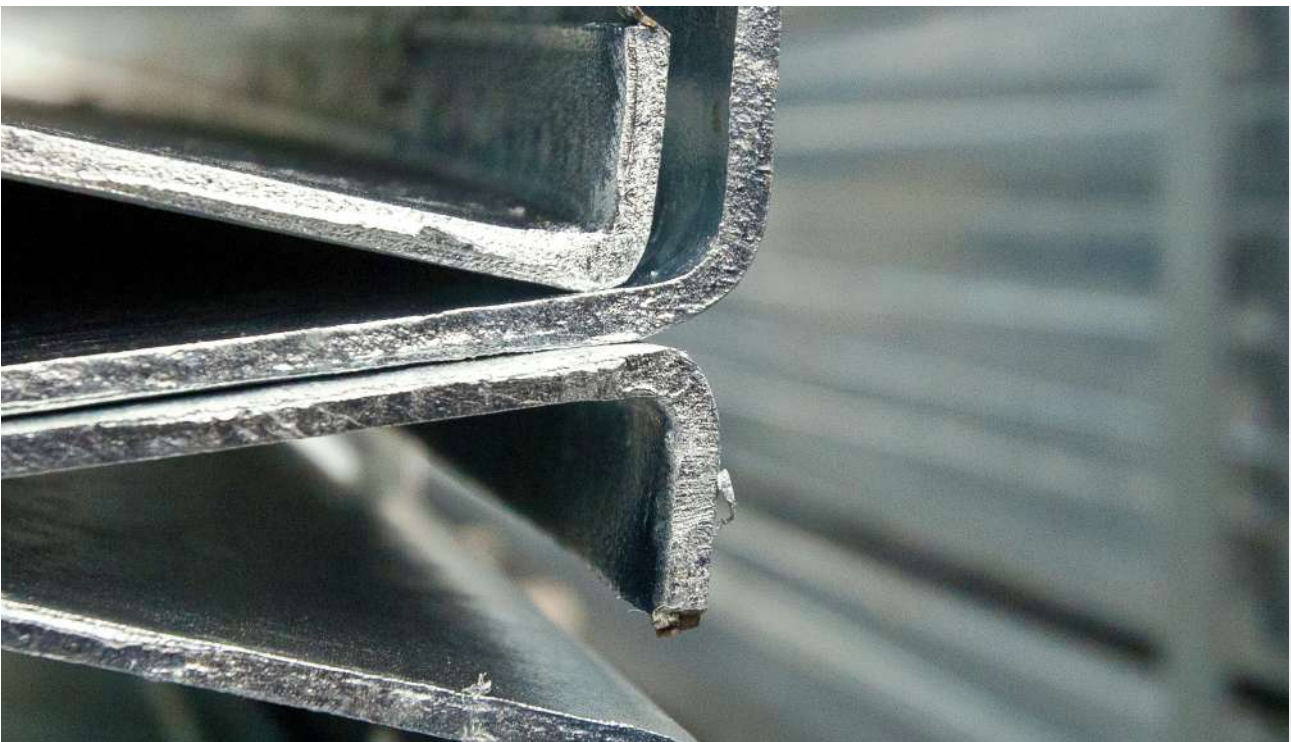

Profiles

Basic offer of steel open profiles

Equal Angle U-Profile

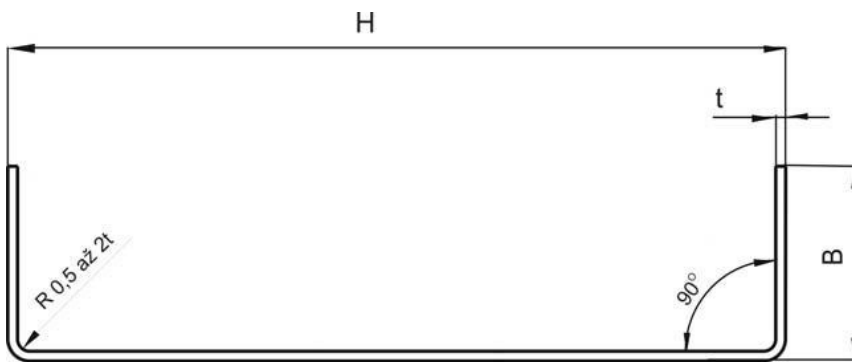

U-Profiles

[H] Prop-Size [mm]	[B] Flange Height [mm]	[t] Thickness [mm]	[H] Prop-Size [mm]	[B] Flange Height [mm]	[t] Thickness [mm]
U-50	25-40	3-5	U-128	38	2
U-54	45	3, 5-4	U-140	49-100	3-6
U-50	50	3-4	U-150	40-75	3-5
U- 60	30-60	2-5	U- 152	40	2, 5
U- 62	45	4	U- 160	40-80	2-6
U- 65	42-55	4, 5-5	U- 162	55	4-5
U- 70	30-50	3-4	U- 180	40-80	3-6
U- 80	30-80	2, 5-6	U- 200	50-100	3-6
U- 90	40-55	2-5	U- 210	49-50	4-6
U- 100	35-70	2-6	U- 220	60-100	4-6
U- 110	70-80	3-4	U- 238	50	5
U- 111	60	4	U- 240	60	2-4
U- 113	25-60	3	U- 250	60-100	5-7
U- 115	25	2-3	U- 272	50	2
U- 120	40-80	3-6	U- 300	40-100	4-6
U- 125	60-90	4	U- 320	40-100	6

By agreement with the plant, equal angle U-profiles can be manufactured in different prop lengths (max. 400 mm) and flange lengths (max. 100 mm). However, with 2.0 mm thickness the developed profile length must not exceed 430 mm width, and with 3.0 up to 7.0 mm thickness it must not exceed 850 mm width.

The flange length must not exceed double prop size. The bend radius can be in the range of 0.5 up to double wall thickness of the profile.

The above-mentioned profiles can be delivered in the lengths ranging from 4.0 up to 12.0 m.

Profiles continued...

C-Profiles

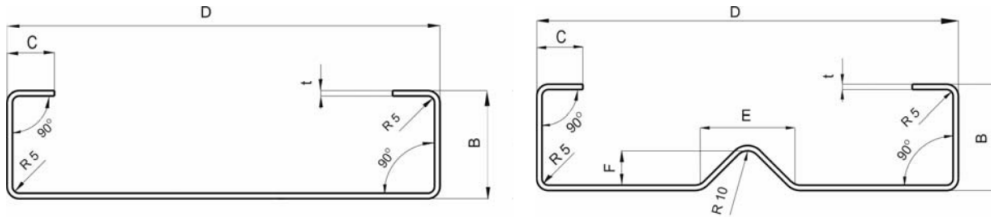

L-Profiles		
[D] Prop Size [mm]	[B] Flange Height [mm]	[t] Thickness [mm]
C-120	55	4
C-240	70	6
C-240	80	4
C-320	80	4
C-240 P	80	4
C-320 P	80	4
C-400 P	80	5
C-480 P	80	5

Note:

C profiles with index “P” are produced in a design with an offset.
 Profile C 240 and C 320 can be manufactured with or without offset.

Extended offer of steel open profiles

Casing Profile

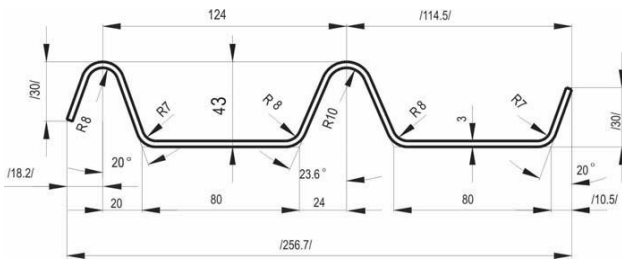

Profile no.	Wall thickness [mm]	Weight [kg/m]
61 009 30	3	8.24

The casing profile is manufactured in monthly sequences.

Extended offer of open steel profiles continued...

Sleeper Profile

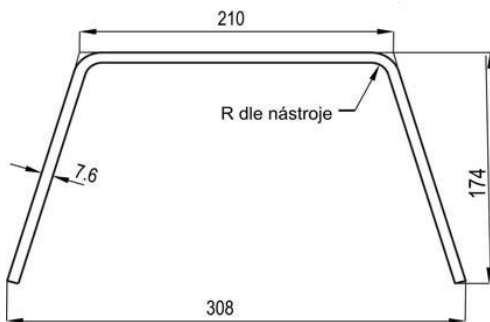

Profile no.	Wall thickness [mm]	Weight [kg/m]
60 501 76	7,6	32,21

Z-Profile

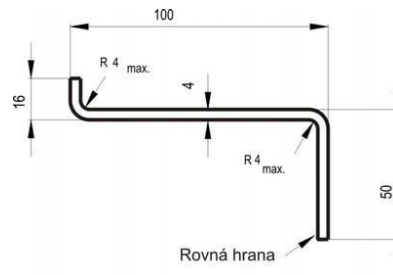

Profile no.	Wall thickness [mm]	Weight [kg/m]
86 501 40	4	4,74

Gate Profile

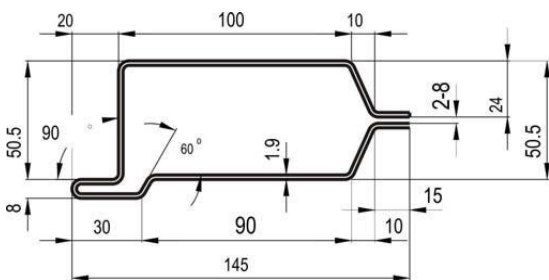

Profile no.	Wall thickness [mm]	Weight [kg/m]
86 501 19	1,9	5,39

Omega Profile

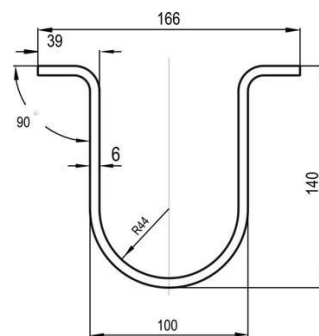

Profile no.	Wall thickness [mm]	Weight [kg/m]
57 504 60	6	17,66

The steel open profiles given in the extended offer except for the casing profile are manufactured in irregular production sequences depending on cumulation of orders.

Profiles continued...

Steel open profiles suitable for manufacture of steel crash barriers and their accessories



Crash barrier profile CZ	Crash barrier profile A NH	Crash barrier profile B NH	Sigma profile (column) 100
--------------------------	-------------------------------	-------------------------------	-------------------------------

In addition to the above mentioned basic profiles, we also offer other profiles such as lower beam AM and beam MOTO or posts C 140x65x4, C 150x75x3,5, V 100x105x4 and V 140x120x5.

Steel open crash barrier profiles are manufactured as a comprehensive offer of crash barriers by European standard.

Specification of order details

The following details are required in enquiries (orders) placed:

Example of details specified in orders	
Required Product	Cold-formed steel open U-profile
Size	U 100 x 50 x 5
Steel grade	EN 10025-2
Surface finish	As rolled - scaled
Required tolerances	EN 10162
Lengths	4-12 m
Length tolerance	0, +100
Max. pack weight	5 t
Min. required quantity	24 t
Required attestations	Attest 3.1 as per EN 10204:1994
Delivery time	May 2021

Contact with the mill

Europe

Liberty Commercial Czech Republic k.s
Vratimovská 689/117, 719 00 Ostrava (CZ)

ID: 05433266

VAT: CZ05433266

E: tomas.hamalcik@libertysteelgroup.com

T: +420 595 684 700

www.libertyostrava.cz

For further information visit **www.libertysteelgroup.com**

Revision: June 2022

